

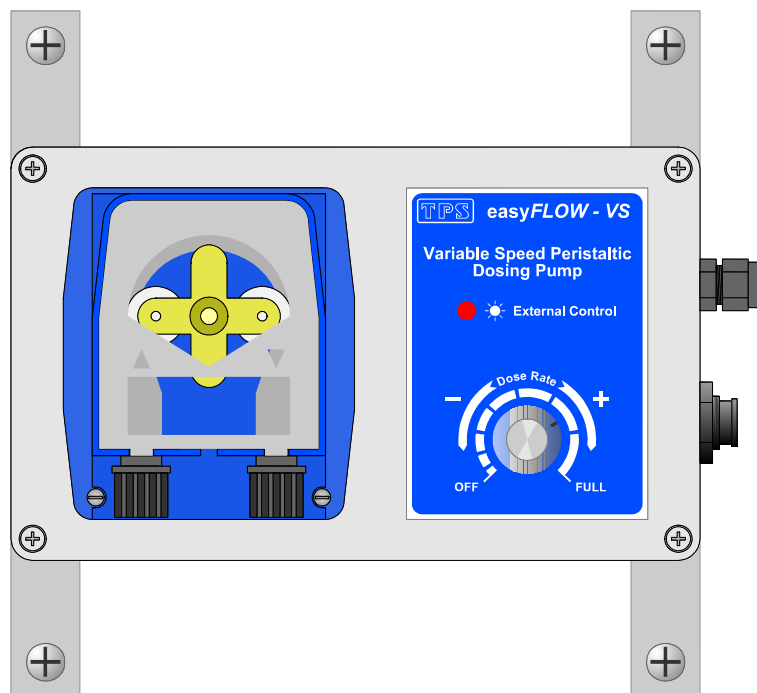

## *easyFLOW-VS Variable Speed Peristaltic Dosing Pump*



### **TPS Pty Ltd**

ABN 30 009 773 371

4 Jamberoo Street  
Springwood, Brisbane,  
Australia, 4127

Phone : (07) 32 900 400  
International : 61 7 32 900 400

Fax : (07) 3808 4871  
International : 61 7 3808 4871

Email : [tps@tps.com.au](mailto:tps@tps.com.au)

Web : [www.tps.com.au](http://www.tps.com.au)

### **easyFLOW-VS User Manual**

Date : 24-Feb-2006  
Author : MS  
Version : 1.2

## Contents

<b>Section 1. – Introduction</b> .....	<b>3</b>
1.1 easyFLOW-VS Illustration .....	4
1.2 Unpacking Information.....	5
1.3 Specifications .....	6
<b>Section 2. – Installation</b> .....	<b>7</b>
2.1 Plan the Installation .....	7
2.2 Install the optional Injection Tee .....	7
2.3 Fit Tubing into Chemical Drum .....	8
2.4 Fit Tubing to Dosing Pump .....	8
2.5 Mount the easyFLOW-VS and Make Electrical Connections .....	9
2.6 External Control Settings.....	10
2.7 Setting the Pump Speed to 50% .....	11
<b>Section 3. – Operating Instructions</b> .....	<b>12</b>
3.1 Manual Operation .....	12
3.2 External On / Off Control Operation .....	12
3.3 External 4-20 mA or 0-1 V Control Operation.....	12
3.4 External 4-20 mA or 0-1 V Control Operation with Manual OFF Override.....	12
3.5 Adjusting the Zero point when using 4-20 mA External Control .....	12
<b>Section 4. – Peristaltic Dosing Pumps</b> .....	<b>13</b>
4.1 Lubricating the Pump Tubing.....	13
4.2 Replacing the Pump Tubing .....	13
<b>Section 5. – Warranty</b> .....	<b>15</b>
<b>Section 6. – Drilling Template</b> .....	<b>17</b>

## Section 1. – Introduction

Thank you for purchasing an **easyFLOW-VS**.

The **easyFLOW-VS** is a high quality peristaltic dosing pump with variable speed control and is designed for maximum reliability to give you many years of reliable service.

The **easyFLOW-VS** is a breeze to operate. If at any stage you require assistance, please contact either your local TPS representative or the TPS factory in Brisbane.

---

The manual is divided into the following sections:

### **Section 1 – Introduction**

The introduction includes a diagram of the **easyFLOW-VS** unit, connectors and controls. Please check the Unpacking Information section to ensure that you have received all accessories and any optional items you may have ordered.

### **Section 2 – Installation**

This section provides details on installing the **easyFLOW-VS**, including all connection and set-up instructions.

### **Section 3 – Operation**

This section provides operational details for **easyFLOW-VS**.

### **Section 4 – Peristaltic Dosing Pump**

A section devoted to the dosing pump fitted to the **easyFLOW-VS**. Describes usage and maintenance instructions.

### **Section 6 – Warranty**

The TPS Warranty conditions are detailed in this section. Also included are details on the procedure to follow in case the **easyFLOW-VS** unit needs to be returned for service or repair.

### **Section 7 – Drilling Template**

This section provides details on installing the **easyFLOW-VS**, including all connection, set-up and operating instructions.

## 1.1 easyFLOW-VS Illustration

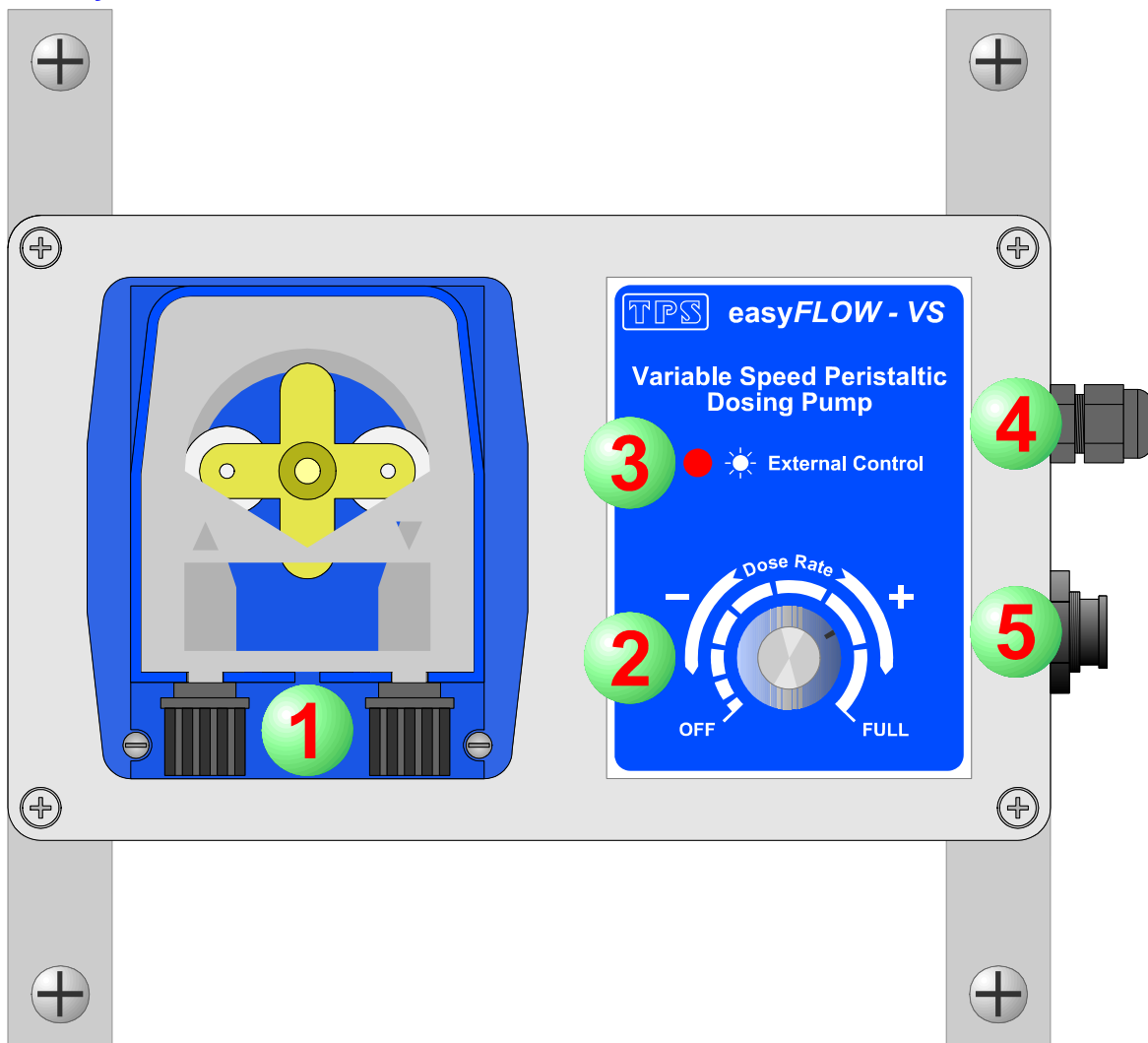





- 1. Peristaltic Dosing Pump**  
 For installation information, see Section 2. – Installation.  
 For usage and maintenance instructions, see Section 4. – Peristaltic Dosing Pumps.
- 2. Dose Rate Control**  
 Adjusts the Litres per Hour at which the **easyFLOW-VS** pumps. This adjustment is not active when the **easyFLOW-VS** is set for external speed control mode using a 4-20mA or 0-1V input.
- 3. External Control Indicator**  
 The External Control indicator LED lights when the **easyFLOW-VS** is set for either external on/off control or external speed control.
- 4. External Control Cable Entry**  
 A waterproof cable gland is provided for use with an external control cable. The unit is supplied with a plastic rod inserted into the gland to ensure the unit is waterproof when no external cable is fitted.
- 5. Power Input Socket**  
 A waterproof connector for the 24V DC power input. An AC/DC adaptor is supplied in the standard **easyFLOW-VS** kit.



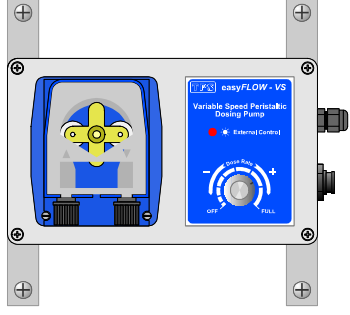
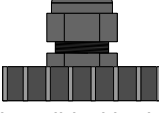

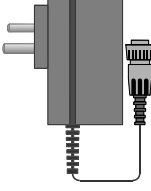
## 1.2 Unpacking Information

Please check that you have received all of the items that should have been included with your new **easyFLOW-VS**, as illustrated below...

### Standard easyFLOW-VS Kit...

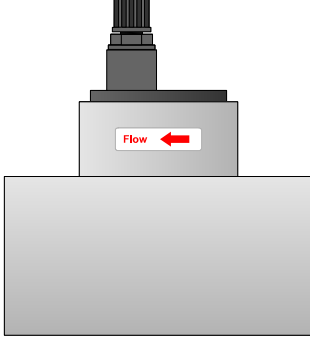
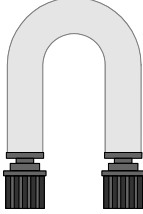
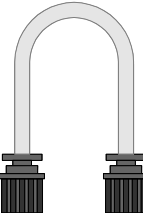
 <p><b>easyFLOW-VS Peristaltic Pump</b> Part No : 118100</p>	 <p>Chemical drum lid with gland fitting Part No : 116362</p>	 <p>Peristaltic Pump Input and Output Tube, 4m. Part No : 116360</p>
 <p><b>24V 500 mA AC/DC Adaptor</b> Part No... 130106 (Australia 240V, 3 Flat Pins) 130108 (Euro/Asia 220V, 2 Round Pins) 130110 (USA 110-120V, 2 Flat Pins) 130112 (UK 240V, Three Pin)</p>	 <p>Tube weight for chemical drum Part No : 116354</p>	 <p><b>easyFLOW-VS Handbook</b> Part No : 130050</p>

### Options and spares...

 <p>Injection Tee for 50mm PVC pipe, with non-return valve Part No : 117901 (Supplied with two reduction bushes to adapt to 40mm pipe)</p>	 <p>Pump tube assembly, 5 L/Hr Part No : 116352</p>  <p>Pump tube assembly, 1.5 L/Hr Part No : 116353</p>	 <p>Pump Tube Lubricant, 3mL Part No : 130103</p>  <p>2-way External Control Cable, 2m Part No : 130128</p>  <p>4-way External Control Cable, 2m Part No : 130130</p>
---	---	--

### 1.3 Specifications

#### **Peristaltic Pump**

- The **easyFLOW-VS** has 1 x built-in Peristaltic Pump.
- Chemical resistant Santoprene pump tubing.
- Small pump tubing produces 1.6 Litres / Hour at Full setting  
Standard large pump tubing produces 5 Litres / Hour at Full setting

#### **Power**

- 24V DC, 500 mA AC/DC Adaptor to suit country of destination is supplied.
- The **easyFLOW-VS** unit draws approximately 200 mA of current.

#### **Standard Control**

- Dose Rate control allows selection of OFF, Dosing Rate and Full speed.

#### **External Control**

- External On and Off switching control, using the Dose Rate setting for constant pump speed.
- External 4-20 mA or 0-1V control which adjusts the speed of the pump according to the input signal.

#### **Calibration**

Zero calibration for 4 – 20 mA External Control operation.

## Section 2. – Installation

### 2.1 Plan the Installation

Ensure that...

1. The **easyFLOW-VS** controller is close enough to the expected location of the injection point for the pump output tubing to reach without straining.
2. The maximum suction height from the bottom of the chemical drums to the dosing pumps is 2 metres.
3. The power lead from the AC/DC Adaptor reaches from a mains power point to the **easyFLOW-VS** without straining.

The external control cable between the **easyFLOW-VS** and the device that is controlling the **easyFLOW-VS** reaches without straining.

### 2.2 Install the optional Injection Tee

If the optional Injection Tee (part no 117901) has been ordered, install it as per the diagram below. Use a suitable PVC joining compound.

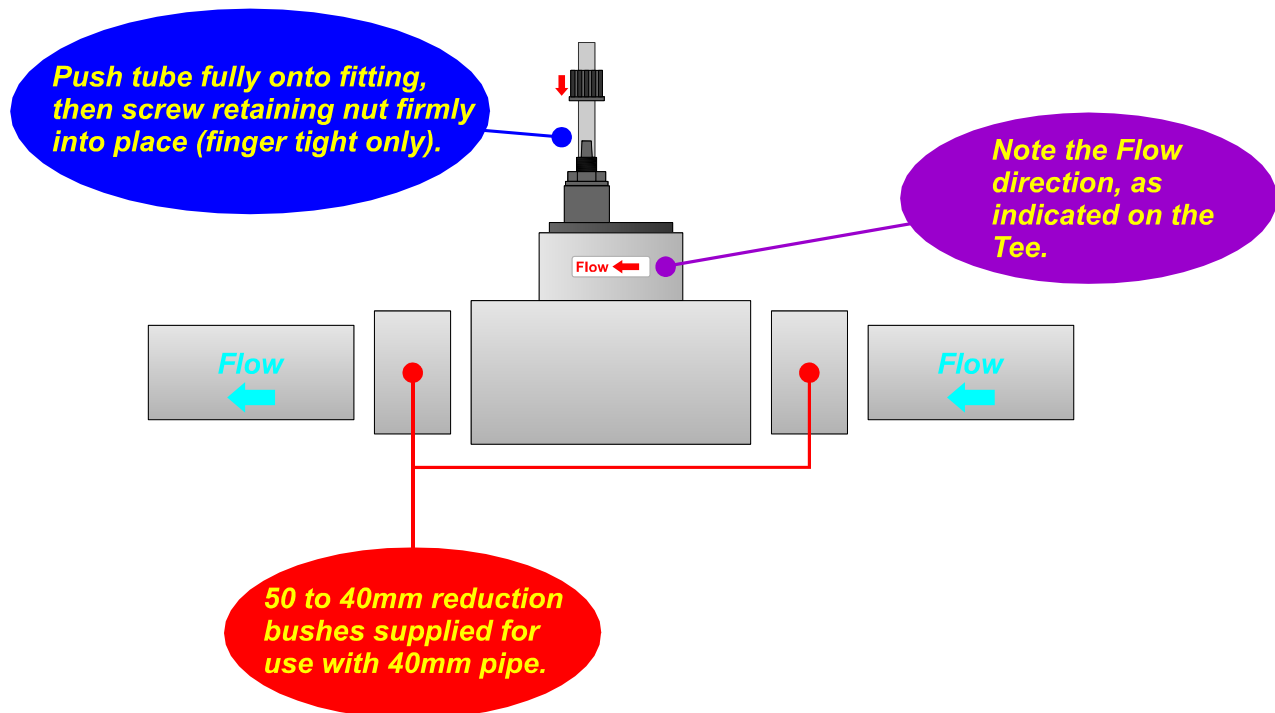

### 2.3 Fit Tubing into Chemical Drum

Insert the suction tubing through the chemical drum lid supplied and fit the drum weight, as per the diagram. For hazardous chemicals be sure to use the correct type of chemical resistant drum. For installations where the lid provided is not compatible with the container, drill a 1/2" or 13mm hole into the lid of the container and fit the compression fitting. Drill a second 2mm diameter vent hole to avoid suction build-up.

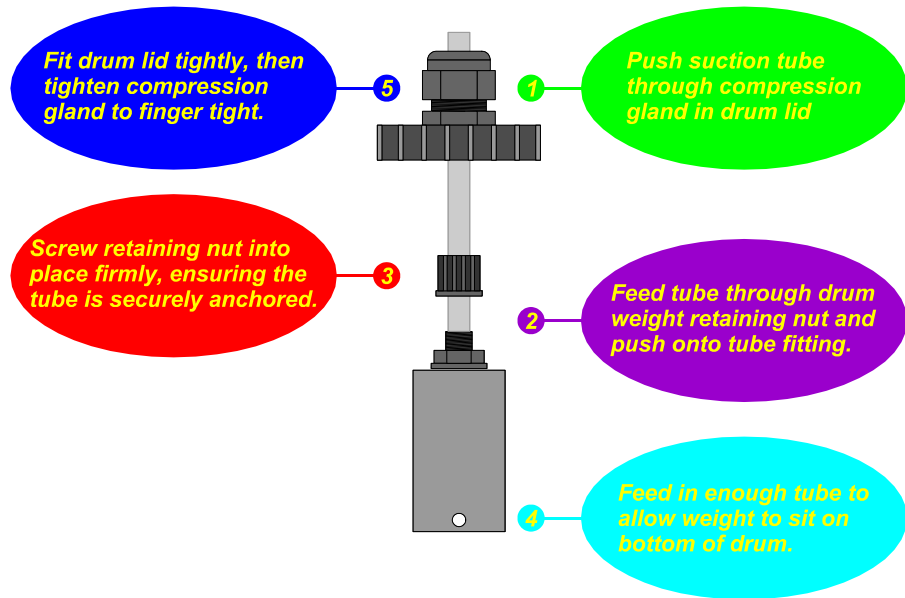

### 2.4 Fit Tubing to Dosing Pump

Insert the suction tubing from the chemical drum to the left hand side compression fitting of the dosing pump. Screw the retaining nut into place firmly, ensuring the tube is securely anchored.

Repeat for the supply tubing on the right hand side of the pump.

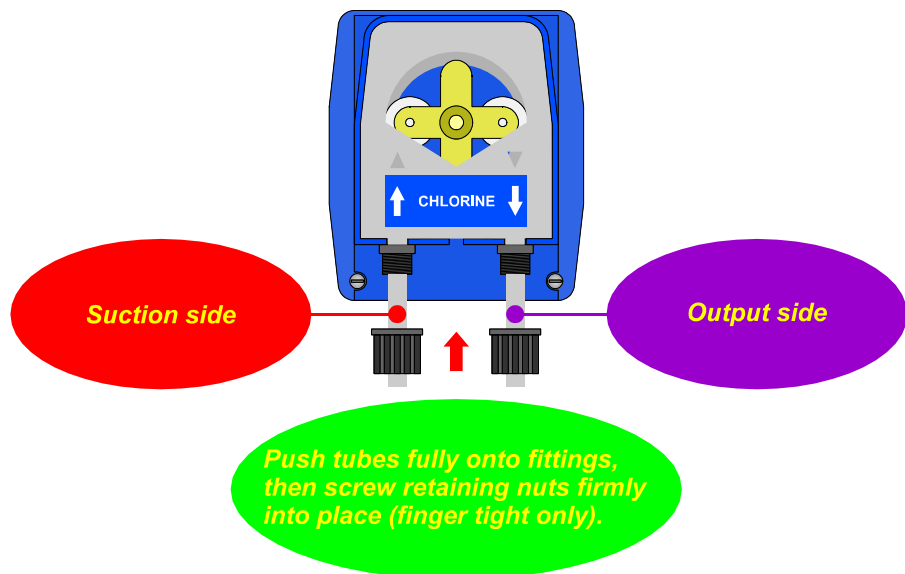

## 2.5 Mount the easyFLOW-VS and Make Electrical Connections

For wall mounting, use minimum 3mm or 1/8" stainless steel bolts, screws or masonry anchors.

**A drilling template is provided at the back of this manual.**

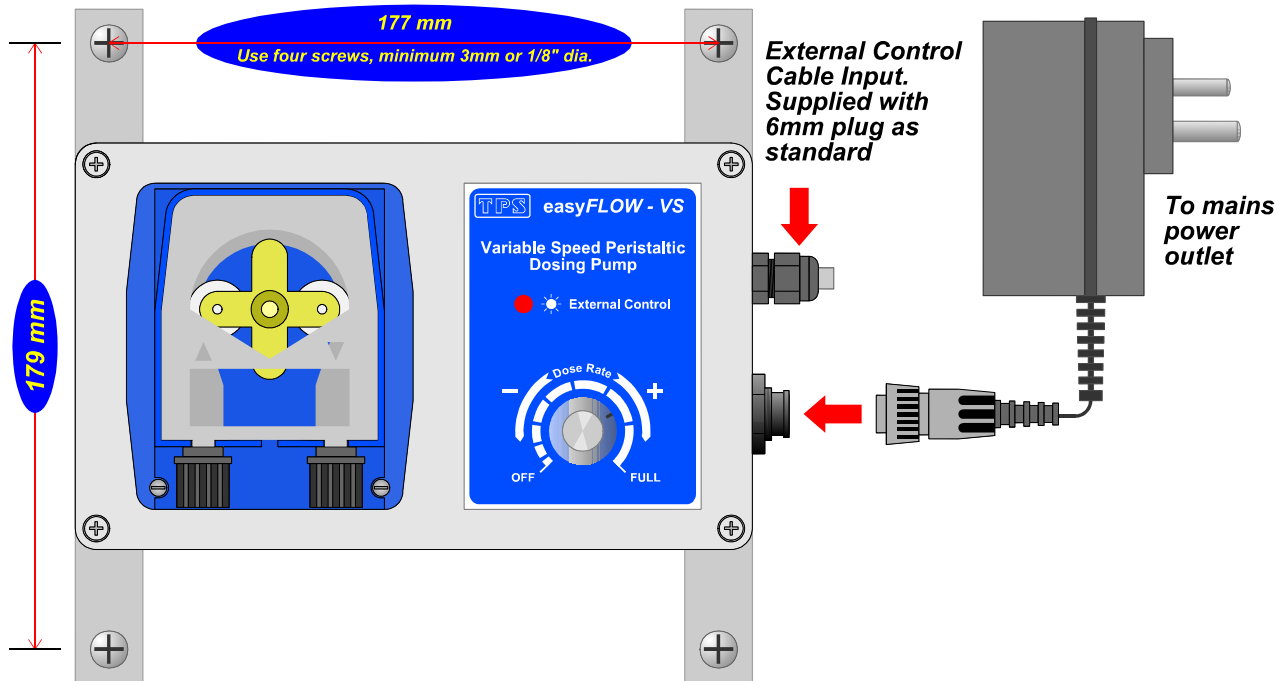

## 2.6 External Control Settings

The **easyFLOW-VS** has the ability to be controlled by an external device. For example, it can be connected to a **miniCHEM** pH controller to control the pH of an industrial process. Using the correct cable connections and jumper settings, the **easyFLOW-VS** can be set up to be externally controlled in the any of the following ways...

1. Simple On and Off switching, operating at the speed setting of Dose Rate control.
2. Variable speed operation, proportional to a 4-20 mA input, where 4mA is stopped and 20mA is full speed.
3. Variable speed operation, proportional to a 0 – 1V DC input, where 0V is stopped and 1V is full speed.
4. Either of the variable speed external control settings above can be set up with a manual override to switch the unit off.

Refer to the following diagram when setting up the External Control connections...

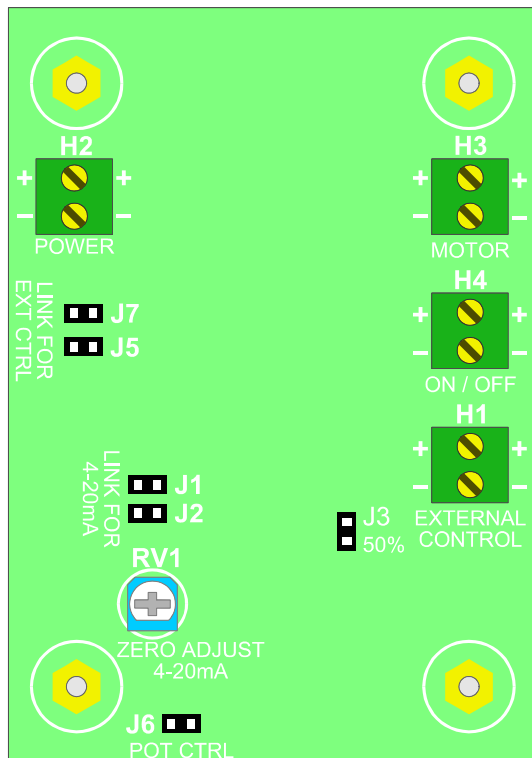

### Notes

To access the circuit board's settings, remove the four screws at the corners of the front panel and remove the lid. Please use caution, to avoid damaging any connecting cables.

In the table below, "Switch" under H4 refers to an external switch to turn the **easyFLOW-VS** on and off. This can be in the form of standard on/off switch or the relay contacts of a process control unit.

"Link" under H4 refers to linking the two terminals with a piece of wire.

When removing jumpers, we recommend that you fit it to one of the pins. This way, it will not be lost if the jumper is to be replaced at a later time.

"n/c" means "No Connection" at that terminal.

External Control Mode	H1	H4	J1	J2	J5	J7	J6
Simple On / Off Switching at Dose rate setting	n/c	Switch	Off	Off	Off	On	On
4-20mA Variable Speed	4-20 mA	Link	On	On	On	On	Off
4-20mA Variable Speed with Manual OFF override	4-20 mA	Switch	On	On	On	On	Off
0-1 V DC Variable Speed	0-1 V	Link	Off	Off	On	On	Off
0-1 V DC Variable Speed with Manual OFF override	0-1 V	Switch	Off	Off	On	On	Off
No external control (factory default settings)	n/c	Link	Off	Off	Off	Off	On

## 2.7 Setting the Pump Speed to 50%

Operators who wish to use the **easyFLOW-VS** at a low speed may find it difficult to set the desired speed accurately with the **Dose Rate** control. A “50%” jumper fitting is provided for these users. To select “50%” speed operation...

1. Remove the front panel and locate the jumper settings, as per the instructions in section 2.6.
2. Set jumper J3 to **On** to select 50% speed operation.
3. If the unit is returned to the factory default **Off** setting at a later time, we recommend that you fit it to one of the pins. This way, it will not be lost if the jumper is to be replaced at a later time.

## Section 3. – Operating Instructions

### 3.1 Manual Operation

The **easyFLOW-VS** is set for manual operation by default.

1. Plug the AC/DC Adaptor into a suitable mains power outlet and switch on.
2. Set the **Dose Rate** control to the desired pump speed.

### 3.2 External On / Off Control Operation

1. Connect the External Control cable as detailed in section 2.6. The cable gland should be finger-tight to ensure a good waterproof seal. Use only round cable, as flat or figure-8 cables will not seal correctly in the gland.
2. Plug the AC/DC Adaptor into a suitable mains power outlet and switch on. Note that the **External Control** LED lights up to indicate that the **easyFLOW-VS** is under external control.
3. Set the **Dose Rate** control to the desired pump speed.

### 3.3 External 4-20 mA or 0-1 V Control Operation

1. Connect the External Control cable as detailed in section 2.6. The cable gland should be finger-tight to ensure a good waterproof seal. Use only round cable, as flat or figure-8 cables will not seal correctly in the gland.
2. Plug the AC/DC Adaptor into a suitable mains power outlet and switch on. Note that the **External Control** LED lights up to indicate that the **easyFLOW-VS** is under external control.
3. It is not necessary to set the **Dose Rate** control as the pump speed is determined by the 4-20 mA or 0–1 V signal.

### 3.4 External 4-20 mA or 0-1 V Control Operation with Manual OFF Override

1. Connect the External Control cable as detailed in section 2.6. The cable gland should be finger-tight to ensure a good waterproof seal. A single round 4 core cable should be used to ensure a waterproof seal at the gland.
2. Plug the AC/DC Adaptor into a suitable mains power outlet and switch on. Note that the **External Control** LED lights up to indicate that the **easyFLOW-VS** is under external control.
3. It is not necessary to set the **Dose Rate** control as the pump speed is determined by the 4-20 mA or 0 – 1 V signal.

### 3.5 Adjusting the Zero point when using 4-20 mA External Control

Every pump motor has a different point at which it starts and stops. This zero point also varies with time. For this reason, a Zero adjustment has been provided when using the 4-20 mA External Control...

1. Set the device that is producing the 4-20mA signal to 4 mA. For a TPS controller, such as a **miniCHEM** or **proCHEM** this can be done by switching the unit to its Limit setting mode and adjusting the Limit to Zero. This will cause the unit to output 4 mA.
2. Adjust the RV1 control until the pump **is running**, then adjust it back until the pump just stops. The Zero point has now been correctly set.

## Section 4. – Peristaltic Dosing Pumps

### 4.1 Lubricating the Pump Tubing

The **easyFLOW-VS** is shipped with the correct lubrication on the peristaltic pump tubing. This lubrication should be re-applied every year. Suitable Silicon lubricant is available from TPS in a 3mL syringe (part no 130103).

To lubricate the pump tubing...

1. Remove the pump tubing, as per the details in section 4.2, below.
2. Smear a small quantity of Silicon grease all around the tube. A thin film is all that is required.

**DO NOT use petroleum based oil or lubricants, as these will cause the Santoprene rubber to perish. Use only Silicon based lubricant.**

### 4.2 Replacing the Pump Tubing

Replace the Pump Tubing if it gets worn, begins to leak, or pumping volume is reduced. The Pump Tubing may be replaced every year as a precautionary measure.

**To remove the old Pump Tube...**

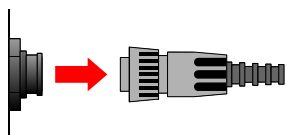
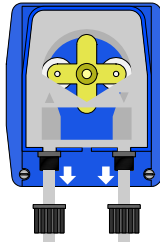
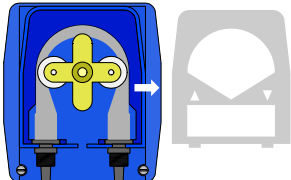
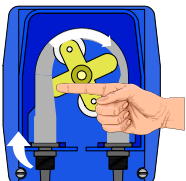
<p style="text-align: center;"><b>1</b></p> <p style="text-align: center;"><b><u>IMPORTANT</u></b></p> <p>Place the pump suction tubing into a bucket of fresh water. Prime the pump with water by switching on at full speed to 3 minutes. This ensures that there is no dangerous chemical in the tube when it is disconnected.</p>	<p style="text-align: center;"><b>2</b></p>  <p>Switch off the power and disconnect the power cord.</p>	<p style="text-align: center;"><b>3</b></p>  <p>Remove the Input and Output tubing from the compression fittings. This is simply a reversal of the procedure detailed in section 2.4.</p>	<p style="text-align: center;"><b>4</b></p>  <p>Remove the see-through protector plate on the front of the pump.</p>
<p style="text-align: center;"><b>5</b></p>  <p>Turn the roller holder so that the rollers are in a horizontal line. Pull the left hand side compression fitting from its seat. Begin turning the roller holder clockwise, so that the roller holder acts as a lever which pulls the pump tube out as it turns. After approximately 3/4 of a turn, the right hand side compression fitting can be pulled out.</p> <p>The old pump tube has now been removed.</p>			

**To fit a new Pump Tube...**

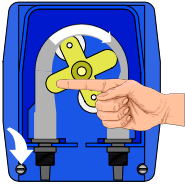
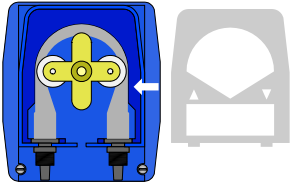
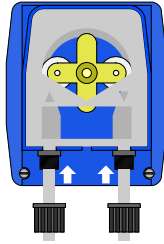
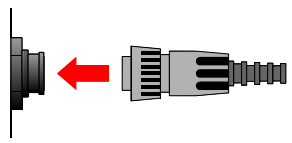
<p style="text-align: center;"><b>1</b></p>  <p>Turn the roller holder so that the rollers are in a horizontal line. Push the left hand side compression fitting into its seat, round side facing in. Begin turning the roller holder clockwise, so that the roller holder acts as a lever which pulls the pump tube in as it turns. After approximately 3/4 of a turn, the right hand side compression fitting can be pushed in, round facing in.</p> <p>The new pump tube has now been fitted.</p>	<p style="text-align: center;"><b>2</b></p>  <p>Replace the see-through protector plate on the front of the pump. This is essential to protect the rollers and tube from dirt and moisture.</p>	<p style="text-align: center;"><b>3</b></p>  <p>Re-fit the Input and Output tubing to the compression fittings. See the procedure detailed in section 2.4.</p>	<p style="text-align: center;"><b>4</b></p>  <p>The power to the <b>easyFLOW-VS</b> can now be re-connected and switched on.</p>
---	--	--	---

**Warning :** Use only a genuine replacement Tube supplied by TPS. Use of other tubing materials, sizes or lengths may place undue stress on the rollers, causing them to wear prematurely. This type of wear is not covered by warranty.

## Section 5. – Warranty

TPS Pty. Ltd. guarantees all instruments and sensors to be free from defects in material and workmanship when subjected to normal use and service. This guarantee is expressly limited to the servicing and/or adjustment of an instrument returned to the Factory, or Authorised Service Station, freight prepaid, within twelve (12) months from the date of delivery, and to the repairing, replacing, or adjusting of parts which upon inspection are found to be defective. Warranty period on sensors is three (3) months.

There are no express or implied warranties which extend beyond the face hereof, and TPS Pty. Ltd. is not liable for any incidental or consequential damages arising from the use or misuse of this equipment, or from interpretation of information derived from the equipment.

Shipping damage is not covered by this warranty.

### **PLEASE NOTE**

A guarantee card is packed with the instrument or sensor. This card must be completed at the time of purchase and the registration section returned to TPS Pty. Ltd. within 7 days. No claims will be recognised without the original guarantee card or other proof of purchase. This warranty becomes invalid if modifications or repairs are attempted by unauthorised persons, or the serial number is missing.

### **PROCEDURE FOR SERVICE**

If you feel that this equipment is in need of repair, please re-read the manual. Sometimes, instruments are received for "repair" in perfect working order. This can occur where the sensor(s) simply requires cleaning or replacement or some other field serviceable event.

TPS Pty. Ltd. has a fine reputation for prompt and efficient service. In just a few days, our factory service engineers and technicians will examine and repair your equipment to your full satisfaction.

To obtain this service, please follow this procedure...

Return the instrument AND ALL SENSORS to TPS freight pre-paid and insured in its original packing or suitable equivalent. INSIST on a proof of delivery receipt from the carrier for your protection in the case of shipping claims for transit loss or damage. It is your responsibility as the sender to ensure that TPS receives the unit.

Please check that the following is enclosed with your equipment:

- **Your Name and daytime phone number.**
- **Your return street address.**
- **A description of the fault. (Please be SPECIFIC.)**  
(Note: "Please Repair" does NOT describe a fault.)

Your equipment will be repaired and returned to you by air express where possible.

For out-of-warranty units, a repair cost will be calculated from parts and labour costs. If payment is not received for the additional charges within 30 days, or if you decline to have the equipment repaired, the complete unit will be returned to you freight paid, not repaired. For full-account customers, the repair charges will be debited to your account.



This page has been intentionally left blank, to ensure that the drilling template is on its own removable page.

**Section 6. – Drilling Template**

**177 mm**

***Use four screws, minimum 3mm or 1/8" dia.***

