

Congratulations !

You have purchased the latest in Handheld Turbidity instrumentation. We trust that your new **WP-89** will give you many years of reliable service.

The **WP-89** is a breeze to operate. This manual has been designed to help you get started, and also contains some handy application tips. If at any stage you require assistance, please contact either your local TPS representative or the TPS factory in Brisbane.

The manual is divided into the following sections:

1. **Table of Contents**

Each major section of the handbook is clearly listed. Sub-sections have also been included to enable you to find the information you need at a glance.

2. **Introduction**

The introduction has a diagram and explanation of the display and controls of the **WP-89**. It also contains a full listing of all of the items that you should have received with your **WP-89**. Please take the time to read this section, as it explains some of items that are mentioned in subsequent sections.

3. **Main Section**

The main section of the handbook provides complete details of the **WP-89**, including operating modes, calibration, troubleshooting, specifications, and warranty terms.

4. **Appendices**

Appendices containing background information and application notes are provided at the back of this manual.

TPS Pty Ltd
4 Jamberoo Street
Springwood, Brisbane,
Australia, 4127

Phone : (07) 32 900 400
International : 61 7 32 900 400
Fax : (07) 3808 4871
International : 61 7 3808 4871
E-mail : tps@tps.com.au
Web Site : www.tps.com.au

Model WP-89 Turbidity Meter

Handbook Version : 1g
Date : 07 Mar 2001
Author : MS

Contents

1. Introduction	4
1.1 WP-89 Display and Controls	4
1.2 Unpacking Information	6
1.3 Specifications	7
2. WP-89 Menu Structure	9
3. Notes on Turbidity Probes & Standards	10
4. Readout Mode	11
4.1 Selecting Absolute Turbidity Readout	11
4.2 Selecting Relative Turbidity Readout	11
4.3 8 Second Averaging	13
5. Calibration	14
5.1 2 Point Calibration Procedure	14
5.2 3 Point Calibration Procedure	16
5.3 Calibration Notes	18
6. Good Laboratory Practices (GLP)	19
6.1 To recall Calibration information on the display	19
6.2 Instrument Serial Number	20
6.3 Additional GLP Features	20
7. Notepad Function	21
7.1 Recording Readings into the Notepad	21
7.2 Recalling Records from the Notepad	21
7.3 Erasing Records from the Notepad	22
7.4 Printing Records from the Notepad to the RS232 Port	23
8. Automatic Datalogging	24
8.1 Programming Automatic Datalogging	24
8.2 Starting and Stopping Automatic Datalogging	25
9. RS232 Port	26
9.1 RS232 Protocol	26
9.2 Sending Readings to the RS232 Port	26
9.3 Communication and Statistical Software	26
9.4 RS232 Commands	27
9.5 Data Format	28
10. Setting the Analogue Output Range	29
11. Battery Care and Maintenance	30
11.1 Battery Saver Function	30

- 12. Clock Function 31**
 - 12.1 Setting the Clock.....31
 - 12.2 Displaying or Hiding the Clock.....31
- 13. Instrument firmware version number. 32**
- 14. Troubleshooting 32**
 - 14.1 General Errors.....32
- 15. Optional Protective Probe Shroud 33**
- 16. Warranty 34**

1. Introduction

1.1 WP-89 Display and Controls

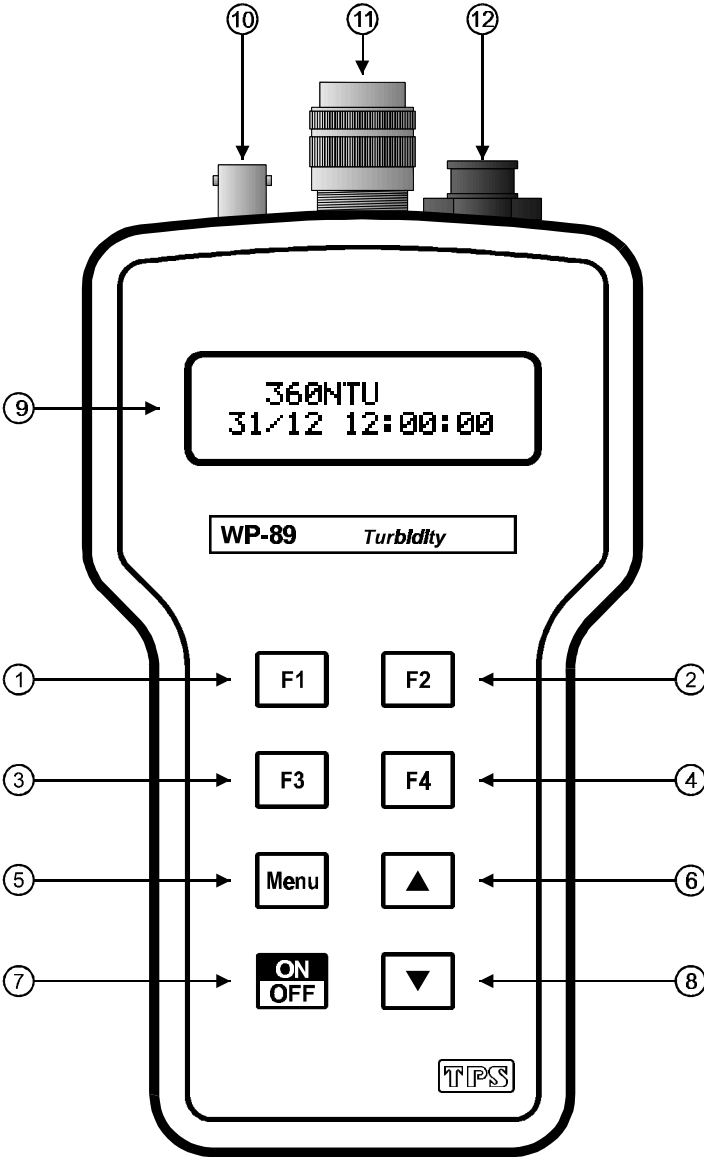



Press to record readings into the Notepad (section 7.1).



Press to show or hide the date and time (section 12.2).



Press to start or stop automatic logging, or view logging status (section 8.2).



Press to transmit current reading plus date and time to the optional RS232 port (section 9.2).



Press to access the user-friendly menu system.

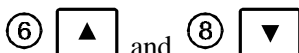

The and keys are used when calibrating (section 5), setting the clock (section 12.1) and setting the automatic logging period (section 8.1).

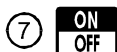

Switches the **WP-89** on and off.

⑨ Display

32 character alpha-numeric display with user-friendly menu and prompting system. Shows turbidity data plus date and time simultaneously.

⑩ Analogue Output

BNC connector for analogue output. Output is 0 to 2 V DC (section 10).

⑪ Probe Connector

Waterproof connector for Turbidity probe.

⑫ Charger / RS232 Connector

Waterproof connector for battery charger and/or optional RS232 cable.

1.2 Unpacking Information

Before using your new **WP-89**, please check that the following accessories have been included...

	Part No
1. WP-89 Turbidity Meter.....	125190
2. High Sensitivity 90 ^o probe, 5m.....	125192
3. Turbidity Standard, Diluted, 360NTU, 200mL.....	125206
4. Battery charger for 240V AC Australian outlet.....	130048
5. WP-89 Handbook.....	130050

*Options that may have been ordered with your **WP-89**...*

1. Stainless steel protective shroud for 90 ^o probe.....	125210
2. Wide Range 180 ^o retro-scatter probe, 5m.....	125194
3. Extended cable for Turbidity probe (order by the metre).....	125196
4. Turbidity Standard, Diluted, 360NTU, 1 Litre.....	125204
5. Turbidity Standard, Primary, 180NTU, 200mL.....	125202
6. Turbidity Standard, Primary, 180NTU, 1 Litre.....	125200
7. RS232 Serial Interface Option.....	125198
(includes cables and communication software for DOS)	
8. WinTPS Communication software for Windows™.....	130086
95, 98 & ME	
9. Hard Carry Case.....	130059
10. Battery charger lead for 12V cigarette lighter socket.....	130046
11. Battery charger lead with clips for 12V DC source.....	130052
12. Solar Panel.....	130012
13. Battery charger for 220V AC European & Asian outlet.....	130060
14. Battery charger for 240V AC UK outlet.....	130062
15. Battery charger for 110/120V AC USA outlet.....	130061

Other spares:

1. 6V NiMH Battery.....	130038
2. RS232 Interface Cable.....	130041

Clock	Calendar clock displays date and time. Date format : dd/mm/yy or mm/dd/yy (user selectable).
Battery Saver.....	On..... Auto switch-off after 5 minutes. Off..... Continuous use. Bar Graph display of battery charge level.
Power.....	6V NiMH Rechargeable Battery.
Dimensions	187 x 110 x 51 mm
Mass	Instrument only ... Approx 500g Full Kit Approx 1.0kg
Environment.....	Temperature..... 0 to 45 °C Humidity..... 0 to 90 % R.H.
Case Rating.....	IP65 with all connectors sealed with dust caps (supplied) or connections in place.
Analogue Output	0 to 2 Volts DC corresponding to preset measuring range. Output impedance is 600 Ω nominal.

2. WP-89 Menu Structure

A detailed breakdown of the menu system of the **WP-89** is shown below. This diagram provides a quick reference for the menu functions available for the **WP-89**.

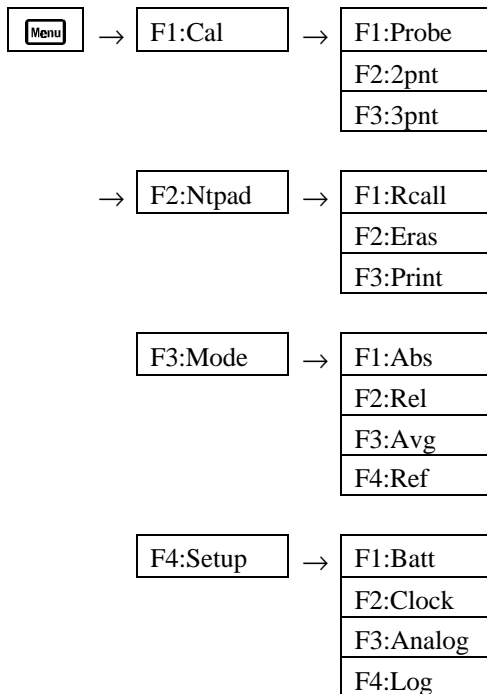

3. Notes on Turbidity Probes & Standards

The probes designed to operate with the NEP160 display units are "smart probes" in that they each carry their own "signature", that is, calibration and characterisation data. Consequently, probes can be connected to any **WP-89** and the display unit is immediately informed of the necessary calibration constants for proper operation. This allows the operator to use more than one probe with the same display unit. Further, probes can be periodically factory-calibrated without the need to return the **WP-89** instrument to the factory also.

On power up the **WP-89** will interrogate the probe socket to determine if a probe is connected, and its parameters. If a probe is not connected the display will show the message "**NO PROBE**". After successful interrogation of a probe, the display will show the message "**probe s/n 12345**" for a short period, where "**12345**" is the probe's serial number. This confirms successful communication with the probe. Probes may be changed over at any time. Immediately after another probe is connected, the display will indicate the serial number of the new probe to show proper communication has taken place and the **WP-89** has the necessary probe information for accurate readings.

Two Turbidity probes are available for use with the **WP-89**. They are...

High Sensitivity Probe, Part No 125192

High sensitivity turbidity probe measuring light scattered at 90° according to ISO7027. It is capable of measuring Turbidity from 0 to 3,000 NTU. This probe can be submersed to a depth of 30m. Standard cable length is 5m, but other lengths can be specified at order.

Wide Range Probe, Part No 125194

General purpose retro-scatter probe that measures light reflected back at 180°. It is capable of measuring Turbidity from 10 to 30,000 NTU. This probe can be submersed to a depth of 30m. Standard cable length is 5m, but other lengths can be specified at order.

Primary and Secondary Turbidity Standards

Primary Turbidity standards, as the name suggests, are formulated from primary materials. They are not diluted in any way and are recommended for users who require utmost accuracy. Primary standards should be used if Turbidity readings are to form the basis of legal proceedings.

Secondary Turbidity standards are made by diluting Primary Turbidity standards. They are as accurate as the volumetric equipment and personnel used in the dilution, as well as the Turbidity of the distilled water used in the dilution. These standards are much lower in cost, and are suitable for most Turbidity measurement requirements.

4. Readout Mode

The **WP-89** has two operating modes – absolute turbidity and relative turbidity. The default mode is absolute turbidity. To select the readout mode...

4.1 Selecting Absolute Turbidity Readout

1. Switch the **WP-89** ON.
2. Select the Mode menu ( → **F3:Mode**).

F1:Abs	F2:Rel
F3:Avg	F4:Ref

3. Press  to select absolute turbidity readout. The **WP-89** will display the actual solution turbidity in NTU (Nephelometric Turbidity Units). Below is an example of an absolute turbidity reading...

360NTU
31/12 12:00:00

4.2 Selecting Relative Turbidity Readout

1. Switch the **WP-89** ON.
2. Select the Mode menu ( → **F3:Mode**).
3. Select **F2:Rel** to select relative turbidity readout. The **WP-89** will display the solution turbidity relative to a preset reference value in NTU (Nephelometric Turbidity Units). Below is an example of a relative turbidity reading. Note the "**REL**", which indicates relative turbidity.

+360NTU REL
31/12 12:00:00



4. The value of the reference solution can either be entered manually, or the current solution can be set as the reference.

Continued over the page...

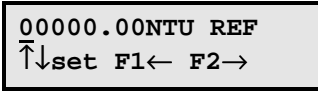

To enter the value of the reference solution manually...

5. Select the Reference solution menu ( → **F3:Mode** → **F4:Ref**).
6. Select **F1:Numer** from the menu. The reference solution setting screen is now displayed...



Press  and  to select the digit to be set.

Press  and  to set the digit

Press and hold the  or  keys to scroll rapidly to the desired value.

Press  at the last digit to save the reference solution value and exit.

Alternatively, press  to quit and retain the current reference solution value.

To set the current solution as the reference value...

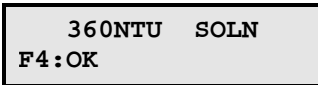

5. Select the Reference solution menu ( → **F3:Mode** → **F4:Ref**).
6. Select **F2:Soln** from the menu. The reference solution setting screen is now displayed...



Allow the reading to stabilise, then press  to store the reading as the reference NTU value.

Alternatively, press  to quit and retain the current reference solution setting.

Press  and  to set the digit

Press and hold the  or  keys to scroll rapidly to the desired value.

Press  at the last digit to save the reference solution value and exit.

4.3 8 Second Averaging

A unique feature of the WP-89 is the 8 second averaging function. By default, this function is switched off. This provides a fast reaction time, and is suitable for measuring solutions where the Turbidity is either stable or changing gradually in one direction.



However, for solutions where the Turbidity is rapidly changing in both directions (such as the base of a brook or weir), the readings can fluctuate so rapidly that it is difficult to obtain a steady reading. The 8 second averaging function is provided for just this situation.

To turn the 8 second averaging function ON or OFF...

1. Select the Mode menu ( → **F3:Mode**).
2. Select **F3:Avg** from the menu.

The 8 second averaging selection menu is now displayed...

8-sec avg is ON
 ↑↓set F1:OK

Use the  and  keys to alternatively select 8 second averaging to be ON or OFF.

Press  to save the new setting.

Alternatively, press  to quit and retain the current setting.

5. Calibration

The probe supplied with the **WP-89** has been factory calibrated before despatch. It should therefore not require re-calibration when the unit is first used.

The **WP-89** may be re-calibrated any time with a 2 point or a 3 point calibration.

Thereafter, the operator can choose to use either the original factory calibration settings or the user calibration settings. See section 6.1 for details on selecting factory or user calibration settings.

5.1 2 Point Calibration Procedure

A 2 point calibration is suitable for most general purpose applications, especially where measurements will be performed over a reasonably narrow range.

1. Connect the probe to the sensor socket and switch the **WP-89** ON.
2. Place the probe into the first turbidity standard solution. This must be a Zero NTU solution, such as filtered distilled water. **DO NOT USE TAP WATER.**

IMPORTANT : Leave at least 25mm clearance from the bottom of the probe to the bottom of the beaker to avoid interference with the reading.

3. Select 2 Point Calibration (**Menu** → **F1:Cal** → **F2:2pnt**).

The reading from the probe is now displayed. For example...

```
0.05NTU pnt1/2
F2:grab
```

4. When the reading has stabilised, press **F2** to GRAB the Zero reading. The **WP-89** will confirm that the first calibration point has been successful...

```
0.00NTU pnt1/2
F2:OK
```

Press **F2** to proceed to the second calibration point.

Press **Menu** to quit and retain the current calibration.

5. Place the probe into a the second turbidity standard solution (eg 360 NTU).

IMPORTANT : Leave at least 25mm clearance from the bottom of the probe to the bottom of the beaker to avoid interference with the reading.

The reading from the probe is displayed. For example...

```
360.3NTU pnt2/2
F2:grab
```

When the reading has stabilised, press **F2** to GRAB the turbidity standard solution reading.

6. The **WP-89** will now allow you to enter the value of the second turbidity standard solution. For example...

```
360.3NTU pnt2/2
F2:OK      ↑↓:set
```

Press **▲** and **▼** to set the value of the turbidity standard solution.

Press **F2** to calibrate the second calibration point.

Alternatively, press **Menu** to quit and retain the current calibration.

5.2 3 Point Calibration Procedure

A 3 point calibration provides the best accuracy for turbidity readings, especially over a broad measurement range. This calibration is recommended for users who require utmost precision, in which case primary turbidity standards should be used.

1. Connect the probe to the sensor socket and switch the **WP-89** ON.
2. Place the probe into the first turbidity standard solution. This must be a Zero NTU solution, such as filtered distilled water. **DO NOT USE TAP WATER.**

IMPORTANT : Leave at least 25mm clearance from the bottom of the probe to the bottom of the beaker to avoid interference with the reading.

3. Select 3 Point Calibration (**Menu** → **F1:Cal** → **F3:3pnt**).

The reading from the probe is now displayed. For example...

```
0.05NTU pnt1/3
F2:grab
```

4. When the reading has stabilised, press **F2** to GRAB the Zero reading. The **WP-89** will confirm that the first calibration point has been successful...

```
0.00NTU pnt1/3
F2:OK
```

Press **F2** to proceed to the second calibration point.

Press **Menu** to quit and retain the current calibration.

5. Place the probe into a the second turbidity standard solution (eg 180 NTU). This must have a Turbidity value higher than the first standard, but lower than the third standard.

IMPORTANT : Leave at least 25mm clearance from the bottom of the probe to the bottom of the beaker to avoid interference with the reading.



The reading from the probe is displayed. For example...

```
180.3NTU pnt2/3
F2:grab
```

When the reading has stabilised, press **F2** to GRAB the turbidity standard solution reading.

6. The **WP-89** will now allow you to enter the value of the second turbidity standard solution. For example...

```
180.3NTU  pnt2/3
F2:OK      ↑↓:set
```

Press  and  to set the value of the turbidity standard solution.

Press  to calibrate the second calibration point.

Press  to quit and retain the current calibration.

7. Place the probe into a the third turbidity standard solution (eg 1800 NTU). This must have a Turbidity value higher than the second standard.

IMPORTANT : Leave at least 25mm clearance from the bottom of the probe to the bottom of the beaker to avoid interference with the reading.



The reading from the probe is displayed. For example...

```
1803NTU  pnt3/3
F2:grab
```

When the reading has stabilised, press  to GRAB the turbidity standard solution reading.

8. The **WP-89** will now allow you to enter the value of the third turbidity standard solution. For example...

```
1803NTU  pnt3/3
F2:OK      ↑↓:set
```

Press  and  to set the value of the turbidity standard solution.

Press  to calibrate the third calibration point.

Press  to quit and retain the current calibration.

5.3 Calibration Notes

1. The **WP-89** will accept any turbidity standards that are entered during calibration, so calibration cannot fail. Ensure that your standards and procedures are correct to ensure that the **WP-89** produces accurate measurements.

6. Good Laboratory Practices (GLP)

Calibration constants are stored in the turbidity probe, and include the date and time of the last calibration.

6.1 To recall Calibration information on the display

1. Select the calibration menu (**Menu** → **F1:Cal**).
2. Select **F1:Probe** from the menu.
3. The model and serial number of the probe which is currently connected is now displayed. For example...

```
type NEP260
s/n 12345   F2:→
```

Press **F2** to proceed to the next screen or **Menu** to quit.

4. The date and time of the last factory calibration is then displayed. For example...

```
31/12/00 12:00
factory   F2:→
```

Press **F2** to proceed to the next screen or **Menu** to quit.

5. The date and time of the last user calibration is then displayed. For example...

```
31/12/01 12:00
user      F2:→
```

Press **F2** to proceed to the next screen or **Menu** to quit.

6. The **WP-89** now offers the choice of using the factory or user calibration settings for turbidity measurements. For example...

```
use USER   cal
↑↓:set     F2:→
```

Press **▲** or **▼** to toggle between using factory or user settings for turbidity measurements. If in doubt, use the factory settings as these turbidity sensors are very stable long term.

Press **F2** to save the setting, or **Menu** to quit and retain the current setting.

If in doubt, use the factory settings as these turbidity sensors are very stable long term.

5. The **WP-89** now reverts to normal operation.

6.2 Instrument Serial Number

In case the serial number that is fitted to the rear of the **WP-89** is removed or becomes illegible, it is also available on the **WP-89** display.

- The serial number is displayed at turn-on, for example...

```
WP89 TURBIDITY  
s/n 12345 ver 1g
```

where **12345** is the serial number.

- The serial number of the probe is displayed when recalling the GLP information (section 6.1).

6.3 Additional GLP Features

Another GLP requirement is to record the date and time of every reading. The **WP-89** does this for you when readings are recorded either with the Notepad function (section 7) or the Automatic Logging function (section 8). Each reading is also stamped with its own log number.

7. Notepad Function

7.1 Recording Readings into the Notepad

To record readings into the Notepad memory...

1. Press **F1** in normal display mode. The display should now look like this:

```

360NTU   #001
F1:yes   F2:no
  
```

A snapshot of the reading has been taken at the time **F1** was pressed.

2. Press **F1** again to record Turbidity reading, Date and Time into the Notepad. This will be labelled as reading number 1.

Press **F2** to quit without recording the reading into the Notepad.

3. Repeat steps 1 & 2 as often as required. The maximum number of readings that can be stored in the Notepad is 100.

7.2 Recalling Records from the Notepad

To recall readings from the Notepad memory...

1. Select the Notepad menu (**Menu** → **F2:NtPad**).
2. Select **F1:Rcall** from the menu.
3. The latest record is now displayed, for example...

```

360NTU
#001 F2:more  ↑↓
  
```

4. Press **▼** to move backward through the records.
Press **▲** to move forward through the records.
Press and hold the **▼** or **▲** keys to scroll rapidly through the readings.
Press **F2** at any time to alternatively display the data or the date and time for each record.
5. Press **Menu** to move exit and return to normal operation.

7.3 Erasing Records from the Notepad

To erase all records from the Notepad...

1. Select the Notepad menu (**Menu** → **F2:Ntpad**).
2. Select **F2:Erās** from the menu.
3. The **WP-89** now asks if you are sure that you wish to erase all records.

ERASE, YOU SURE? F1:yes F2:no
--

4. Press **F1** to erase all records from the Notepad
Press **F2** to quit without erasing the records from the Notepad.

7.4 Printing Records from the Notepad to the RS232 Port

This function is only available when the optional RS232 port is fitted.

1. Connect one end of the RS232 cable to the **Charger/RS232** socket of the **WP-89**. The charger, optional solar panel, or optional car battery lead can be connected into the spare socket on the cable for long term use if required.
2. Connect the other end of the RS232 cable to an RS232 Printer, or to the COM1 or COM2 ports of a PC.
3. Ensure that the baud rate for the printer or PC and the **WP-89** are the same (4800 baud).

If necessary, alter the baud rate of the printer or PC.

The **WP-89** uses XON/XOFF protocol. Ensure that the printer is set accordingly.

4. Select the Notepad menu ( → **F2:Ntpad**).
5. Select **F3:Print** from the menu.

Printing starts as soon as  is pressed. The display shows the word “**Printing**” until printing is completed.

8. Automatic Datalogging

The **WP-89** can automatically log records into the Notepad. First the logging period must be programmed, then automatic logging can be started and stopped as required.

8.1 Programming Automatic Datalogging

1. Select the Log menu (**Menu** → **F4:Setup** → **F4:Log**).
2. The display should now look like this:

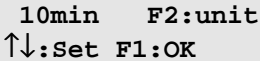

10min F2:unit
↑↓:Set F1:OK

3. Use the **▲** and **▼** keys to set the period at which the **WP-89** will automatically log records, from 1 to 99.
4. When the logging period has been correctly set, select whether this period is in minutes or seconds.
Press **F2** to alternatively select minutes or seconds as the units.
5. Press **F1** when the desired logging period and units have been set.
Alternatively, press **Menu** to quit and retain the current setting.
6. The **WP-89** now offers the choice of logging into the instrument's memory or directly to the RS232 port...

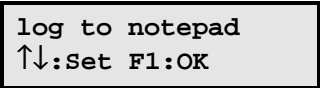

log to notepad
↑↓:Set F1:OK

Use the **▲** and **▼** keys to choose between logging to the instrument's Notepad memory or logging directly to the RS232 port.

Press **F1** to save the setting.

Alternatively, press **Menu** to quit and retain the current setting.

7. The automatic logging function is now programmed, and can be started and stopped as required (see section 8.2).

8.2 Starting and Stopping Automatic Datalogging

1. To start automatic logging, press **F3** in normal display mode.

The current Automatic Datalogging status is displayed, for example...

When logging to
Notepad...

```
stopped 10m #001
F4:start   F3:OK
```

or:

When logging to RS232
port...

```
stopped 10m ser
F4:start   F3:OK
```

Press **F4** to start automatic datalogging.

Press **F3** to quit without starting automatic datalogging.

When logging into the instrument's memory, the unit will display the message "**AUTO LOGGING**" momentarily each time a reading is recorded.

When logging directly to the RS232 port, the unit will beep each time a reading is sent.

2. To stop automatic logging, press **F3** in normal display mode.

The current Automatic Datalogging status is displayed, for example...

When logging to
Notepad...

```
logging 10m #100
F4:stop    F3:OK
```

or:

When logging to RS232
port...

```
logging 10m ser
F4:stop    F3:OK
```

Press **F4** to stop automatic datalogging.

Press **F3** to quit without stopping automatic datalogging.

Note:

The clock must be set before the **WP-89** will allow automatic logging to start. The message "**Clock Not Set**" is displayed if the clock is not set. See section 12.1 for details on setting the clock.

9. RS232 Port

This section is applicable if the optional RS232 port is fitted.

9.1 RS232 Protocol

The **WP-89** RS232 configuration is 8 bits, No Parity, 1 Stop Bit, XON/XOFF Protocol. The baud rate is fixed at 4800.

9.2 Sending Readings to the RS232 Port

Press **[F4]** to instantly send readings to the RS232 port whenever the **WP-89** is in normal measurement mode.

Records can be sent directly to the RS232 port rather than stored in memory during automatic datalogging. See section 8 for details.

9.3 Communication and Statistical Software

Communication between the **WP-89** and a PC can be handled with any RS232 communication software. WinTPS Communication software for Windows™ 95, 98 and ME is optionally available (Part No 130086).

Once the data is saved to disk, the next problem is how to use it. The data is formatted in columns that can be imported by programs such as Microsoft® Excel® and Lotus 123®.

Information on how to use the software is provided in the WinTPS manual on the WinTPS CD-ROM.

9.4 RS232 Commands

The following commands can be sent from a PC to the **WP-89**. Note that <cr> denotes carriage return and <lf> denotes a line feed.

Action	Command	Notes
Request current data	?D<cr>	Returns the current Turbidity data, date and time from the WP-89 . The log number returned is set to Zero. Data format A
Request logged data	?R<cr>	Returns all logged records from the WP-89 memory. The data ends with the message ENDS <cr>. Data format B
Erase logged data	?E<cr>	Erases all logged records from the WP-89 memory. Returns the message ERASED <cr> to confirm that the records have been erased.
Request status information	?S<cr>	Returns the model name, the Reference NTU value, and number of logged readings in memory. Data format D
Request instrument information	?W<cr>	Returns the firmware version in the NEP160, followed by the meter and probe (if attached) serial numbers. Data format E.

See section 9.5 for details of the data formats.

9.5 Data Format

Data is returned by the WP-89 in the following formats...

Format	Structure	Notes
A	dd/mm/yy*hh:mm:ss*LLL*DDDDDD*NTU*MMM<cr>	?D<cr>
B	dd/mm/yy*hh:mm:ss*LLL*DDDDDD*NTU*MMM<cr> ENDS<cr>	?R<cr>
C	dd/mm/yy*hh.mm.ss*LLL*DDDDDD*NTU* <cr><lf>	Automatic logging to RS232 port (section 8).
D	NEP160***999*RRRRRR<cr>	
E	NEP160*Vx.x*D#####*P#####<cr>	D= Instrument serial no. P= Probe serial no.

Where...

- ♦ represents 1 space.
- dd/mm/yy** is the date/month/year, each two digits. The format is mm/dd/yy (month/date/year) if mm/dd/yy date format has been selected (see section 12.1).
- hh:mm:ss** is the time in hours:minutes:seconds format based on a 24 hour clock.
- LLL** is the log number. Maximum 3 characters, right justified.
- DDDDDD** is the Turbidity data. 6 characters including sign and decimal point, right justified.
- NTU** is the turbidity unit of measurement (nephelometric turbidity units).
- MMM** is the measurement mode – **ABS** for absolute data or **REL** for relative data.
- 999** represents the total number of logged readings in memory. Maximum 3 characters, right justified.
- RRRRRR** is the Reference NTU value. 6 characters including sign (always positive) and decimal point, right justified.
- x.x** is the instrument firmware version number. 3 characters with the middle being a decimal point.
- D#####** Represents the instrument's serial number. Total 6 characters, right justified.
- P#####** Represents the probe's serial number (only if probe is attached). Total 6 characters, right justified.

10. Setting the Analogue Output Range

The analogue output is constantly available on the BNC socket next to the main probe connector (see ⑩ in the diagram in section 1.1).

The analogue output has a full scale of 0 to 2.0V DC corresponding to the range selected. The available ranges are 20, 200, 2000 and 20000 NTU.

To select the range for the analogue output...

1. Select the Setup menu (Menu) → **F4: Setup**).
2. Select **F3: Analog** from the menu. The current full scale value is now displayed, for example...

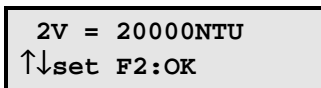

2V = 20000NTU
↑↓set F2:OK

Use the ▲ and ▼ keys to select the full scale which will correspond to an output of 0 to 2.0V DC.

3. Press **F2** to save the new setting.

Alternatively, press **Menu** to quit and retain the current setting.

11. Battery Care and Maintenance

The **WP-89** is fitted with a NiMH battery that is charged using the in-built controller to maximise life and operating time between charges.

When shipped, the battery may be in a discharged state, in which case it will require at least 10 hours charging before use. Thereafter a full charge will be achieved in less than 5 hours of charging. The battery can be left on constant charge without damage but we recommend it be fully discharged at least once every 3 months.

To fully discharge the battery, disable the Battery Saver function (see section 11.1) and leave the unit switched on (without the charger connected). The **WP-89** switches itself off when the battery is discharged.



11.1 Battery Saver Function

The **WP-89** is equipped with a battery saver function. If no button has been pressed for five minutes, the unit will shut off. This function can be disabled for continuous use.

To enable or disable the battery saver function...

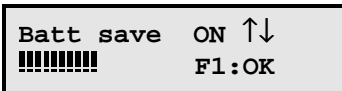
1. Select Battery Saver Set-up ( → **F4:Setup** → **F1:Batt**).
2. The battery saver menu is now displayed. The bar graph indicates the approximate level of charge in the battery. For example...



Use the  and  keys to alternatively select **ON** or **OFF**.

ON enables the battery saver function. The meter will switch itself off if no key has been pressed for five minutes.

OFF disables the battery saver function for continuous use.

4. Press  to save the new battery saver setting.

Alternatively, press  to quit the battery saver menu and retain the current setting.

Note

The bar graph flashes when the battery volts drops below 5.60 volts. At 5.00 volts the meter turns itself off.

12. Clock Function

12.1 Setting the Clock

1. Select the Clock Set-up menu (**Menu** → **F4:Setup** → **F2:Clock**).
2. The **WP-89** now offers the choice of date format...

```
dd/mm/yy hh:mm
↑↓:set F1:← F2:→
```

Use the **▲** and **▼** keys to select between **dd/mm/yy** or **mm/dd/yy** date format.

Press **F2** to move on to setting the date and time.

3. The display now shows the current date and time. The cursor starts at the day (or month), for example...

```
31/12/01 12:00
↑↓:set F1:← F2:→
```

3. Press the **▲** and **▼** keys until the day (or month) is correct.
4. Press **F2** to move to the month (or day). Press the **▲** and **▼** keys until the month (or day) is correct.
5. Press **F2** to move to the year. Press the **▲** and **▼** keys until the year is correct.
6. Press **F2** to move to the hour. Press the **▲** and **▼** keys until the hour is correct.
7. Press **F2** to move the cursor to the minutes. Press the **▲** and **▼** keys until the minutes are correct.
8. Check that the date and time are correct.

Press **F2** to save the settings.

If any changes are needed, press the **F1** key to move left to the desired position.

Alternatively, press **Menu** to quit without resetting the clock.

12.2 Displaying or Hiding the Clock

By default, the date and time are shown on the bottom line of the display, below the Turbidity data. Press the **F2** key to alternatively display or hide the clock.

13. Instrument firmware version number.

If you need to phone or fax TPS for any further technical assistance, the version number of your **WP-89** firmware may of benefit to us. The version number is displayed by the **WP-89** at turn-on.

14. Troubleshooting

14.1 General Errors

Error Message	Possible Causes	Remedy
Meter displays the word OFF , and switches off.	Battery is below 5.00 volts.	Recharge the battery. If this fails, check the charger. If charger OK, replace the battery.
Meter will not turn on.	Battery is exhausted.	Recharge the battery. If this fails, check the charger. If charger OK, replace the battery.
Battery does not charge up when charger is connected.	<ol style="list-style-type: none"> 1. Faulty battery charger. 2. Faulty battery. 	<ol style="list-style-type: none"> 1. Connect the charger and switch the power on. 2. Display the battery charge bar graph in the battery saver menu (see section 11.1). 3. If the bar graph slowly increases then the charger is OK. If the bar graph does not increase, then the charger is faulty. 4. Replace the charger or the battery, as required.

15. Optional Protective Probe Shroud

The optional protective shroud illustrated below is available for high sensitivity 90⁰ probe. The part number for the protector is 125210.

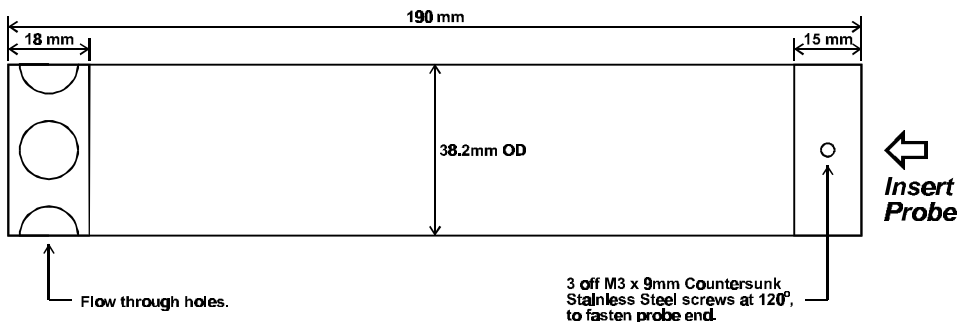

To fit the protective shroud...

1. Insert the 90⁰ high sensitivity probe (part no 125192) into the shroud as shown. Ensure the end of the probe is against the internal stop at the other end of the shroud.
2. **IMPORTANT**
Connect the probe to the **WP-89**. Place probe and shroud assembly into a beaker of distilled water. Leave at least 25mm clearance from the bottom of the probe to the bottom of the beaker. Rotate the probe within the shroud so as to give the lowest possible reading.
3. Fasten the M3 screws onto the probe end. **DO NOT OVERTIGHTEN.**
4. Re-calibrate the **WP-89** and probe with the shroud fitted, as per section 5.

16. Warranty

TPS Pty. Ltd. guarantees all instruments and probes to be free from defects in material and workmanship when subjected to normal use and service. This guarantee is expressly limited to the servicing and/or adjustment of an instrument returned to the Factory, or Authorised Service Station, freight prepaid, within twelve (12) months from the date of delivery, and to the repairing, replacing, or adjusting of parts which upon inspection are found to be defective. Warranty period on probes is three (3) months.

There are no express or implied warranties which extend beyond the face hereof, and TPS Pty. Ltd. is not liable for any incidental or consequential damages arising from the use or misuse of this equipment, or from interpretation of information derived from the equipment.

Shipping damage is not covered by this warranty.

Please Note

A guarantee card is packed with the instrument or probe. This card must be completed at the time of purchase and the registration section returned to TPS Pty. Ltd. within 7 days. No claims will be recognised without the original guarantee card or other proof of purchase. This warranty becomes invalid if modifications or repairs are attempted by unauthorised persons, or the serial number is missing.

Procedure For Service

If you feel that this equipment is in need of repair, please re-read the manual. Sometimes, instruments are received for "repair" in perfect working order. This can occur where batteries simply require replacement or re-charging, or where the probe simply requires cleaning or replacement.

TPS Pty. Ltd. has a fine reputation for prompt and efficient service. In just a few days, our factory service engineers and technicians will examine and repair your equipment to your full satisfaction.

To Obtain This Service, Please Follow This Procedure

Return the instrument AND ALL PROBES to TPS freight pre-paid and insured in its original packing or suitable equivalent. INSIST on a proof of delivery receipt from the carrier for your protection in the case of shipping claims for transit loss or damage. It is your responsibility as the sender to ensure that TPS receives the unit.

Please check that the following is enclosed with your equipment:

- **Your Name and daytime phone number.**
- **Your company name, ORDER number, and return street address.**
- **A description of the fault. (Please be SPECIFIC.)**
(Note: "Please Repair" does NOT describe a fault.)

Your equipment will be repaired and returned to you by air express where possible.

For out-of-warranty units, a repair cost will be calculated from parts and labour costs. If payment is not received for the additional charges within 30 days, or if you decline to have the equipment repaired, the complete unit will be returned to you freight paid, not repaired. For full-account customers, the repair charges will be debited to your account.

- **Always describe the fault in writing.**
- **Always return the probes with the meter.**