

## **Congratulations !**

You have purchased the latest in Handheld pH-mV-Temperature instrumentation. We trust that your new **WP-80** will give you many years of reliable service.

The **WP-80** is a breeze to operate. This manual has been designed to help you get started, and also contains some handy application tips. If at any stage you require assistance, please contact either your local TPS representative or the TPS factory in Brisbane.

---

The manual is divided into the following sections:

### **1. Table of Contents**

Each major section of the handbook is clearly listed. Sub-sections have also been included to enable you to find the information you need at a glance.

### **2. Introduction**

The introduction has a diagram and explanation of the display and controls of the **WP-80**. It also contains a full listing of all of the items that you should have received with your **WP-80**. Please take the time to read this section, as it explains some of items that are mentioned in subsequent sections.

### **3. Main Section**

The main section of the handbook provides complete details of the **WP-80**, including operating modes, calibration, troubleshooting, specifications, and warranty terms.

### **4. Appendices**

Appendices containing background information and application notes are provided at the back of this manual.

TPS Pty Ltd  
4 Jamberoo Street  
Springwood, Brisbane,  
Australia, 4127

Phone : (07) 32 900 400

International : 61 7 32 900 400

Fax : (07) 3808 4871

International : 61 7 3808 4871

E-mail : tps@tpssite.com.au

Web Site : www.tpssite.com.au

## **Model WP-80 pH-mV-Temp. Meter**

Handbook Version : 3.3

Date : 13 Jul 98

Author : MS

## Contents









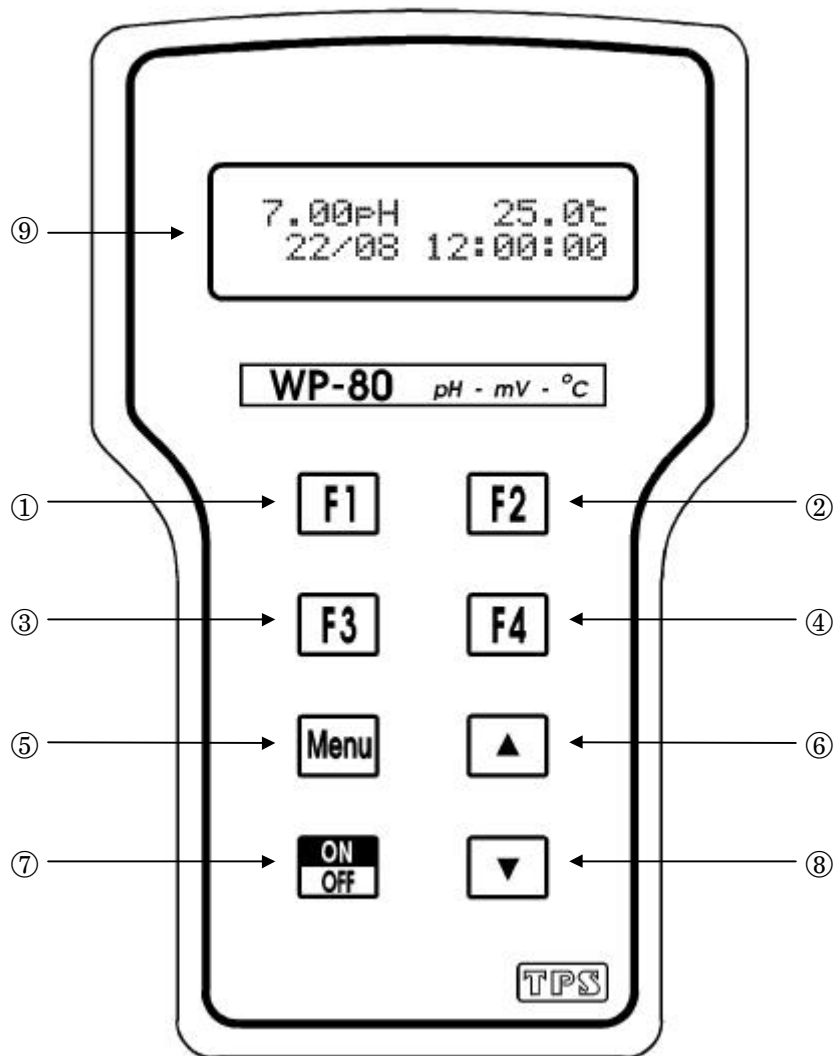

<b>1. Introduction.....</b>	<b>4</b>
1.1 WP-80 Display and Controls.....	4
1.2 Unpacking Information.....	6
1.3 Specifications .....	7
<b>2. WP-80 Menu Structure.....</b>	<b>8</b>
<b>3. Operating Modes.....</b>	<b>9</b>
<b>4. pH Calibration .....</b>	<b>10</b>
4.1 Calibration Procedure .....	10
4.2 Calibration Notes.....	11
4.3 Calibration Messages.....	11
<b>5. mV Calibration .....</b>	<b>11</b>
<b>6. Relative mV Calibration .....</b>	<b>12</b>
6.1 Notes.....	12
<b>7. Temperature Calibration.....</b>	<b>13</b>
7.1 Calibration Procedure .....	13
7.2 Calibration Notes.....	13
7.3 Calibration Messages.....	13
7.4 Manual Temperature Setting .....	14
<b>8. Good Laboratory Practices (GLP) .....</b>	<b>15</b>
8.1 To recall GLP information on the display .....	15
8.2 Failed Calibration .....	15
8.3 Printing GLP Information to the RS232 Port .....	16
8.4 Instrument Serial Number .....	16
8.5 Additional GLP Features .....	16
<b>9. Notepad Function .....</b>	<b>17</b>
9.1 Recording Readings into the Notepad.....	17
9.2 Recalling Records from the Notepad.....	17
9.3 Erasing Records from the Notepad.....	17
9.4 Printing Records from the Notepad to the RS232 Port .....	18
<b>10. Automatic Datalogging.....</b>	<b>19</b>

<b>11. RS232 Port .....</b>	<b>19</b>
11.1 Setting the Baud Rate.....	20
11.2 Sending Readings to the RS232 Port .....	20
11.3 RS232 Configuration .....	20
11.4 Communication and Statistical Software .....	20
11.5 Commands .....	21
11.6 Data Format.....	22
<b>12. Battery Saver Function.....</b>	<b>23</b>
<b>13. Clock Function.....</b>	<b>24</b>
13.1 Setting the Clock .....	24
13.2 Displaying or Hiding the Clock.....	24
<b>14. Selecting pH6.88 or pH7.00 as the Primary Buffer .....</b>	<b>25</b>
<b>15. Initialising the WP-80.....</b>	<b>25</b>
<b>16. Troubleshooting.....</b>	<b>26</b>
16.1 General Errors .....	26
16.2 pH and mV Troubleshooting.....	27
16.3 Temperature Troubleshooting .....	28
<b>17. Warranty .....</b>	<b>29</b>
<b>18. Appendices .....</b>	<b>31</b>
18.1 pH Electrode Fundamentals .....	31
18.2 Checking the reference junction of a pH electrode.....	33
18.3 Determining if an instrument or electrode is faulty.....	34
18.4 Instrument firmware version number.....	34

# 1. Introduction

## 1.1 WP-80 Display and Controls



- ①  Press to record readings into memory. See section 9.1.  
Also used to select pH6.88 or pH7.00 as the primary buffer. See section 14.
- ②  Press to show or hide the date and time. See section 13.2.
- ③  Press to start or stop automatic logging. See section 10.  
Alternatively, press to transmit current reading plus date and time to the RS232 port (optional) See section 11.2.
- ④  Press to zero relative mV, when relative mV mode is selected. See section 6.
- ⑤  Press to access the user-friendly menu system which makes the **WP-80** a breeze to operate.
- ⑥  and ⑧  The  and  keys are used when calibrating temperature readout (section 7), setting manual temperature compensation (section 7.4), setting the clock (section 13.1), setting the automatic logging period (section 10), and displaying GLP information (section 8.1).  
The  key is also used to initialise the **WP-80** at turn-on. See section 15.
- ⑦  Switches the **WP-80** on and off.
- ⑨ **Display**  
32 character alpha-numeric display with user-friendly menu and prompting system. Shows pH/mV and temperature simultaneously. Date and time can also be displayed.

## 1.2 Unpacking Information

Before using your new **WP-80**, please check that the following accessories have been included:

	Part No
1. <b>WP-80</b> pH-mV-Temperature Instrument.....	121109
2. Combination pH Sensor .....	121207
3. Temperature/ATC Sensor.....	121247
4. pH6.88 Buffer, 200mL.....	121306
5. pH4.00 Buffer, 200mL.....	121381
6. Battery charger .....	130037
7. <b>WP-80</b> Handbook.....	130050

Options that may have been ordered with your **WP-80**:

1. RS232 Serial Interface Option.....	130039
(includes cable and communication software for DOS)	
Communication software for Windows® 3.1, 3.11 .....	130086
and 95	
2. Hard Carry Case .....	130059
3. Battery charger lead for 12V cigarette lighter socket .....	130046
4. Solar Panel.....	130012
5. RS232 Printer .....	130031

Other spares:

1. 6V NiMH Battery .....	130038
2. RS232 Interface Cable .....	130041

**1.3 Specifications**

Ranges	: 0 to 14.00 pH 0 to $\pm 500.0$ and 0 to $\pm 1500$ mV (auto-ranging) -10.0 to +120.0 °C
Resolution	: 0.01 pH 0.15 and 1 mV 0.1 °C
Accuracy	: $\pm 0.01$ pH $\pm 0.3$ and $\pm 1$ mV $\pm 0.2$ °C
Memory	: 150 readings including date and time
Automatic Logging	: User-set for one reading every 1 to 90 seconds or minutes.
RS232 Output (optional)	: 300, 1200 & 9600 baud. 8 bits, no parity, 1 stop bit, XON/XOFF Protocol.
Clock	: Calendar clock displays date, month, hours, minutes & seconds. Year is recorded in memory and transmitted to optional RS232 port, but is not displayed.
Battery Saver	: On : Auto switch-off after 5 minutes Off : Continuous use Bar Graph display of battery charge level. Readout of battery voltage available for troubleshooting.
Good Laboratory Practices	: Date, Time and Value of last asymmetry and last slope calibration are stored, and can be recalled or sent to the optional RS232 port at any time.
Input Impedance	: $>3 \times 10^{12} \Omega$
Asymmetry Range	: -1.00 to 1.00 pH
Slope Range	: 85.0 to 105.0%
Temperature Compensation	: 0 to 100.0 °C, automatic or manual
Power	: 6V NiMH Rechargeable Battery for approx 50 hours operation.
Dimensions	: 187 x 110 x 51 mm
Mass	: Instrument only : Approx 440g Full Kit : Approx 1.7kg
Environment	Temperature : 0 to 45 °C Humidity : 0 to 90 % R.H.

## 2. WP-80 Menu Structure

A detailed breakdown of the menu system of the **WP-80** is shown below. This diagram provides a quick reference for the menu functions available for the **WP-80**.

Press the function keys in normal display mode, to perform the following tasks:

- F1 : Press to record current data plus date and time into memory.  
 F2 : Press to show or hide date and time.  
 F3 : Press to start and stop automatic logging.  
 If logging period is set to zero, press to transmit current reading plus date and time to the RS232 port.  
 F4 : Press to zero Relative mV, when Relative mV mode is selected.  
 Menu : Press to access the user-friendly menu system, as detailed below.

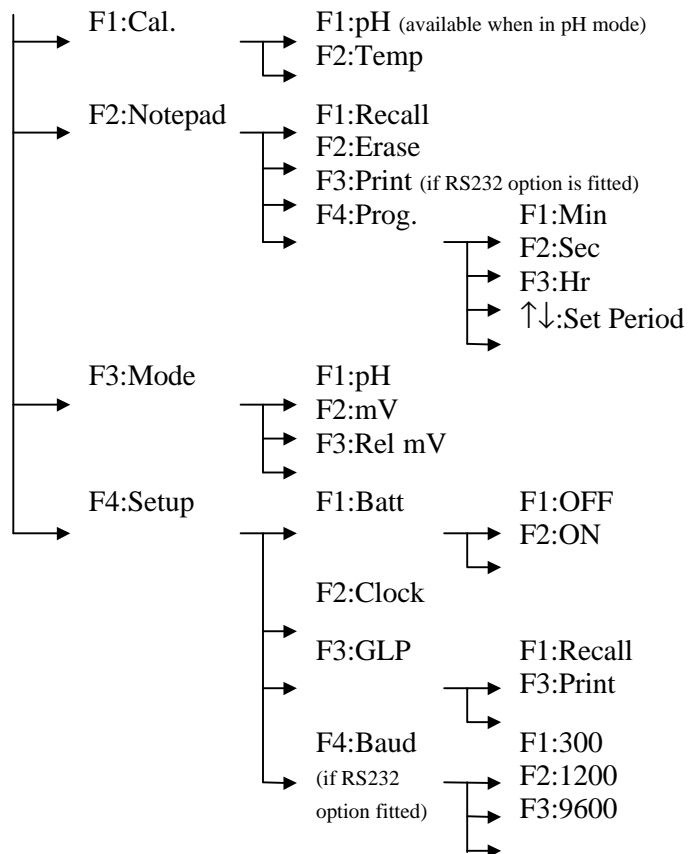

### **3. Operating Modes**

The **WP-80** has three operating modes : pH, mV and Relative mV.

To select a mode, access the mode menu by pressing **Menu**, then **F3:Mode**.

#### **1. F1:pH**

Displays pH and Temperature readings simultaneously. Press **F2** to show or hide the date and time.

eg : **7.00pH 25.0°C**  
**31/1212:00:00**

If the temperature probe is unplugged, the manual temperature setting is displayed with 1°C resolution.

eg:**7.00pH Man 25°C**  
**31/1212:00:00**

#### **2. F2:mV**

Displays mV and Temperature readings simultaneously. Press **F2** to show or hide the date and time.

eg:**1000mV25.0°C**  
**31/1212:00:00**

If the temperature probe is unplugged, no temperature value is displayed.

eg:**1000mV**  
**31/1212:00:00**

#### **3. F3:Rel mV**

Displays Relative mV and Temperature readings simultaneously. Press **F2** to alternatively show absolute mV or the date and time.

eg:**1000mVR25.0°C** or **1000mVR25.0°C**  
**600mVF4:Zeros** **31/12 12:00:00**

If the temperature probe is unplugged, no temperature value is displayed.



eg:**1000mVR** or **1000mVR**  
**600mVF4:Zeros** **31/12 12:00:00**

#### **4. Notes**

- 1) Temperature compensation does not apply in mV mode.
- 2) The decimal point is replaced by a \* if a pH or Temperature calibration has failed (sections 4.1, and 7.1) if the unit is initialised (section 15), or if the unit has lost its factory calibration (section 16.1).



## 4. pH Calibration

### 4.1 Calibration Procedure



1. Plug the pH sensor into the **pH/mV** socket and the temperature sensor into the **Temperature** socket.
2. Switch the meter on. 
3. Select pH Mode.  → **F3:Mode** → **F1:pH**
4. Ensure that temperature has already been calibrated, or manually set (see sections 7.1 and 7.4). NOTE: If the decimal point in the temperature reading is shown by a \*, then the temperature readout is not calibrated.
5. Remove the wetting cap from the pH sensor.
6. Rinse the pH and Temperature sensors in distilled water and blot them dry.
7. Ensure that you are using the primary buffer for which the **WP-80** has been set (see section 14).

Place both electrodes into a small sample of pH6.88 (or pH7.00) buffer, so that the bulb and reference junction are both covered.

**DO NOT** place the electrodes directly into the buffer bottle.

8. Select pH Calibration.  → **F1:Cal.** → **F1:pH**
9. When the reading has stabilised, press the  key to calibrate. If a 1 point calibration has been performed, the \* will not be removed until a full 2 point calibration has been performed.
10. Rinse the pH and Temperature electrodes in distilled water and blot them dry.
11. Place both sensors into a small sample of pH4.00 or pH9.23 Buffer, so that the bulb and reference junction are both covered. **DO NOT** place the electrodes directly into the buffer bottle.

**NOTE:** **pH9.23 buffer is highly unstable. Avoid using this buffer if possible. Discard immediately after use.**

12. Select pH Calibration  → **F1:Cal.** → **F1:pH**
13. When the reading has stabilised, press the  key to calibrate. The \* will now be replaced by a decimal point, if calibration was successful.
14. The **WP-80** is calibrated and ready for use. Discard the used samples of buffer.

## 4.2 Calibration Notes

1. A 1-point calibration should be performed at least weekly. In applications where the electrode junction can become blocked, such as dairy products, mining slurries etc, a 1-point calibration may have to be done daily.
2. A full 2-point calibration should be performed at least monthly. Of course, more frequent calibration will result in greater confidence in results.
3. All calibration information is retained in memory when the **WP-80** is switched off, even when the battery is removed. This information can be recalled or printed later using the GLP function (see section 8).
4. The **WP-80** displays the value of the pH buffer to which it will attempt to calibrate. Ensure that the buffer value displayed corresponds to the buffer that you are using.

## 4.3 Calibration Messages

1. If a 1-point calibration has been successfully performed, the **WP-80** will display the following message, and the asymmetry of the electrode.

eg: **1 Point Cal.OK**  
**Asy= 0.10pH**

2. If a 1-point calibration has failed, the **WP-80** will display the following message, and the failed asymmetry value of the electrode.

eg: **1 Point Cal.Fail**      or:      **1 Point Cal.Fail**  
**Asy= 1.50 Hi**                      **Asy=-1.50 Lo**

3. If a 2-point calibration has been successfully performed, the **WP-80** will display the following message, and the asymmetry and slope of the electrode.

eg: **2 Point Cal.OK**              then:      **2 Point Cal.OK**  
**Asy= 0.10pH**                      **Slope=100.0%**

4. If a 2-point calibration has failed, the **WP-80** will display the following message, and the failed slope value of the electrode.

eg: **2 Point Cal.Fail**              or:      **2 Point Cal.Fail**  
**Slope=130.0% Hi**                      **Slope= 70.0% Lo**

## 5. mV Calibration

The mV section is factory calibrated. There is no user-calibration facility for this mode.

## 6. Relative mV Calibration

Select Relative mV mode when measurements relative to a known standard are required. Calibration of the Relative mV mode is simply a matter of zeroing the reading when the sensor is in the known standard.

1. Plug the Redox sensor into the **pH/mV** socket. Temperature compensation is not applied in Relative mV mode, so the temperature sensor does not need to be connected.

2. Switch the meter on.



3. Select Relative mV Mode



→ **F3:Mode** → **F3:Rel mV**

The display should now be showing Relative mV on the top line with absolute mV or date and time on the bottom line.

eg: **1000mVR25.0°C**      or      **1000mVR25.0°C**  
**500mVF4:Zeros**              **31/12 12:00:00**

Press **[F2]** to alternate between absolute mV or the clock on the bottom line.

4. Remove the wetting cap from the Redox sensor.

5. Rinse the sensor in distilled water and blot dry.

6. Place the Redox sensor into a sample of the known standard. Ensure that the platinum tip and reference junction are both covered. When the reading has stabilised, press the **[F4]** key to zero the Relative mV reading. The Relative mV reading will now be zero, and the absolute mV reading will remain unchanged.

eg: **0mVR 25.0°C**              or      **0mVR 25.0°C**  
**500mVF4:Zeros**              **31/12 12:00:00**

7. The **WP-80** Relative mV mode is now zeroed and is ready for use. The readout can be re-zeroed by pressing the **[F4]** key whenever required.



### 6.1 Notes

1. The Relative mV offset is retained in memory when the **WP-80** is switched off, even when the battery is removed.
2. The Relative mV zero is reset when leaving Relative mV mode (see section 3)





## 7. Temperature Calibration

The temperature readout must be calibrated or manually set before attempting pH calibration. The decimal point is replaced by a \* if the reading is not calibrated.

### 7.1 Calibration Procedure

1. Plug the temperature sensor into the **Temperature** socket.
2. Switch the meter on. 
3. Place the sensor into a beaker of room temperature water, alongside a good quality mercury thermometer. Stir the probe and the thermometer gently to ensure an even temperature throughout the beaker.
4. Select Temperature Calibration  → **F1:Cal.** → **F2:Temp**
5. The reading from the probe is now displayed on the right of the display, and the value you are going to set is shown on the left.

eg: → **25.0** ← **20\*0°c**  
 ↑↓:Set **F1:Cal.**

6. When the reading on the right has stabilised, press the  and  keys until the reading on the left shows the same temperature as the mercury thermometer.
7. Press the  key to calibrate the temperature readout.  
 Alternatively, press the  key to abort temperature calibration.

### 7.2 Calibration Notes

1. Temperature calibration information is retained in memory when the **WP-80** is switched off, even when the battery is removed. This information can be recalled later using the GLP function (see section 8).
2. Temperature does not need to be recalibrated unless the Temperature probe is replaced or the meter is initialised.

### 7.3 Calibration Messages

1. If a temperature calibration has been successfully performed, the **WP-80** will display the following message and the offset value of the probe.



eg: **Calibrate OK**  
**Offset= 1.0°c**

2. If a temperature calibration has failed, the **WP-80** will display the following message, and the failed offset value of the probe.

eg: **Calibrate Fail**  
**Offset= 10.5°c**



## 7.4 Manual Temperature Setting

If the temperature sensor is not connected, the temperature of the sample solution must be set manually for accurate pH measurements. A separate thermometer will be required for this.

1. Switch the meter on. 
2. Measure the temperature of the sample.
3. Select Temperature Calibration  → **F1:Cal.** → **F2:Temp**
4. The current temperature setting is now displayed.

eg: → **25.0** ← **Man Temp**

↑↓:**Set**      **F1:Save**





5. Press the  and  keys until the display shows the temperature of the sample.
6. Press the  key to save the temperature value.

Alternatively, press the  key to quit and retain the current setting.

## 8. Good Laboratory Practices (GLP)

The **WP-80** keeps a record of the date and time of the last pH asymmetry, pH slope and Temperature offset calibrations as part of GLP guidelines.

### 8.1 To recall GLP information on the display

1. Switch the meter on. 
2. Select the GLP menu.  → **F4:Setup** → **F3:GLP**
3. Select recall. **F1:Recall**
4. The instrument model, firmware version number, and instrument serial number are displayed, along with a prompt describing how to scroll through the GLP information.  
eg: **WP80 V2.0 R1234**  
**↓:More ↑:Back**
5. Press the  key to sequentially scroll through the GLP information for all parameters. Press the  key to scroll back to previous data. The sequence of information displayed is shown below. Press  to abort at any time.

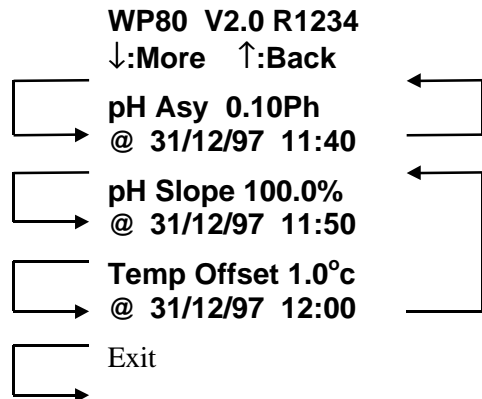

### 8.2 Failed Calibration

If calibration has failed, the GLP function will reset the date and time to zero. The **WP-80** still shows the results of the last successful calibration.

eg: **pH Asy 0.10pH**      **pH Slope 100.0%**      **Temp Offset 1.0°C**  
**@ 00/00/00 00:00**      **@ 00/00/00 00:00**      **@ 00/00/00 00:00**

Note that these calibration values are still used if further measurements are taken without recalibrating.

### 8.3 Printing GLP Information to the RS232 Port

The GLP information stored in the instrument's memory can be sent to a printer or PC via the RS232 port. This function is available only when the optional RS232 port is fitted.

1. Switch the meter on. 
2. Ensure that the **WP-80** RS232 cable is connected to the instrument and to the printer or PC.
3. Send the GLP information to the RS232 port:

 → **F4:Setup** → **F3:GLP** → **F3:Print**

4. The GLP information is sent to the RS232 port in formatted ASCII text.

eg: WP80 V2.0 R1234 @ 31/12/97 12:00  
 pH Asy= 0.00pH @ 31/12/97 11:00  
 pH Slope= 100.0% @ 31/12/97 11:10  
 Temperature Offset= 1.0oC @ 31/12/97 11:20  
 ENDS

### 8.4 Instrument Serial Number

In case the serial number that is fitted to the rear of the **WP-80** is removed or becomes illegible, it is also available on the **WP-80** display.

- The serial number is displayed at turn-on,

eg: **WP-80 V2.0 R1234**

**pH mV Temp.**

where **R1234** is the serial number.

- The serial number is displayed when recalling the GLP information (section 8.1).
- The serial number is included on the printout of GLP information (section 8.3).

### 8.5 Additional GLP Features

Another GLP requirement is to record the date and time of every reading. The **WP-80** does this for you when readings are recorded either with the Notepad function (section 9) or the Automatic Logging function (section 10).

## **9. Notepad Function**

### **9.1 Recording Readings into the Notepad**

To record readings into the Notepad memory:

1. Press **F1** in normal display mode. The display should now look like this:

eg: **7.00pH**            **25.0°C**

**F1: 1**            **12:00:00**

2. If you now press **F1**, the pH, Temperature, Date and Time will be recorded into the notepad, and labelled as reading number 1.
3. Repeat steps 1 & 2 as often as required. The maximum number of readings that can be stored in the Notepad is 150.

### **9.2 Recalling Records from the Notepad**

To recall records from the Notepad onto the **WP-80** display:

1. Select the Notepad menu **Menu** → **F2:Notepad**
2. Select Recall from the menu **F1:Recall**
3. Record number 1 is now displayed,

eg: **7.00pH**            **25.0°C**

**# 1**            **F2:Clock**

4. Press **F2** to alternatively display the date and time or the data for this record.  
Press **▲** to move forward through the records.  
Press **▼** to move backward through the records.  
Press and hold the **▲** or **▼** keys to roll rapidly through the readings.

### **9.3 Erasing Records from the Notepad**

To erase all records from the Notepad:

1. Select the Notepad menu **Menu** → **F2:Notepad**
2. Select Erase from the menu **F2:Erase**
3. The **WP-80** now asks if you are sure that you wish to erase all records.

**Erase, You Sure?**

**F1:Yes F2:No**

4. Press **F1** to erase all records from the Notepad  
Press **F2** to quit without erasing the records from the Notepad.

#### 9.4 Printing Records from the Notepad to the RS232 Port

This function is only available when the optional RS232 port is fitted.

1. Connect one end of the RS232 cable to the **Charger/RS232** socket of the **WP-80**. The charger, optional solar panel, or optional car battery lead can be connected into the spare socket on the cable for long term use, if required.
2. Connect the other end of the RS232 cable to an RS232 Printer, or to COM1 or COM2 of a PC.
3. Ensure that the baud rate for the printer or PC and the **WP-80** are the same.

If necessary, alter the baud rate of the **WP-80** (see section 11.1).

The **WP-80** uses XON/XOFF protocol. Ensure that the printer is set accordingly.

4. Select the Notepad menu. Menu → **F2:Notepad**
5. Select Print from the menu. **F3:Print**

Printing starts as soon as F3 is pressed. The display shows the word “**Printing**” until printing is completed.

## **10. Automatic Datalogging**

The **WP-80** can automatically log records into the Notepad. First the logging period must be programmed, then automatic logging can be started and stopped as required.

1. Select the Program menu → **Menu** → **F4:Notepad** → **F4:Program**

2. The display should now look like this:

eg: →00← **F1:Min**      **F2:Sec**  
 ↑↓:**Set Period**      **F3:Hr**

3. Use the **▲** and **▼** keys to set the period at which the **WP-80** will automatically log records.

4. When the logging period has been correctly set, select whether this period is in minutes or seconds.

Press **F1** to save the period as minutes.

Press **F2** to save the period as seconds.

Press **F3** to save the period as hours.

eg: If the period was set to **05**, followed by **F2**, then the **WP-80** will automatically log a record every 5 seconds.

5. If the optional RS232 port is fitted, the **WP-80** will ask if the records are to be logged into the Notepad, or sent directly to the RS232 port.

Press **F1** to log records into the Notepad (maximum of 150 readings).

Press **F3** to send records directly to the RS232 port.

6. The automatic logging function is now programmed, and can be started and stopped as required.

7. To start automatic logging, press **F3** in normal display mode.

If the **WP-80** is logging into the Notepad, the display will look like this:

eg: **7.00pH**      **25.0°C**  
**Log# 1**      **12:00:00**

The log number will increment and the **WP-80** will beep each time a reading is recorded.

If the **WP-80** is sending records directly to the RS232 port, the display will look like this:

eg: **7.00pH**      **25.0°C**  
**Sending**      **12:00:00**

The **WP-80** will beep each time a record is sent to the RS232 port.

8. Press **F3** to stop automatic logging.

9. **Note:** The clock must be set before the **WP-80** will allow automatic logging to start. The message "**Clock Not Set**" is displayed if the clock is not set.

## **11. RS232 Port**

This section is applicable if the optional RS232 port is fitted.

### 11.1 Setting the Baud Rate

1. Select the RS232 Set-up menu **[Menu]** → **F4:Setup** → **F3:Baud**
2. The available baud rates are listed on the display.  
ie:     **F1:300**     **F2:1200**  
      → **F3:9600**

The arrow shows the current selection.

3. Press **[F1]** to select 300 baud

Press **[F2]** to select 1200 baud

Press **[F3]** to select 9600 baud.

Press **[Menu]** to quit and retain the current setting.

### 11.2 Sending Readings to the RS232 Port

Press **[F3]** to instantly send readings to the RS232 port whenever the **WP-80** is in normal run mode. This function is disabled if the automatic logging period is set to greater than zero (see section 10).

Records can be sent directly to the RS232 port rather than stored in memory during automatic datalogging. See section 10 for details.

### 11.3 RS232 Configuration

The **WP-80** RS232 configuration is 8 bits, No Parity, 1 Stop Bit, XON/XOFF Protocol.

### 11.4 Communication and Statistical Software

Communication between the **WP-80** and a PC can be handled with any RS232 communication software. The diskette supplied by TPS contains a BASIC program for this purpose. A Windows version is also optionally available.

Once the data is saved to disk, the next problem is how to use it. The data is formatted in columns that can be imported by programs such as Microsoft<sup>®</sup> Excel<sup>®</sup> and Lotus 123<sup>®</sup>.

Information on how to use the software is provided in the README files on the diskette.

## 11.5 Commands

The following commands can be sent from a PC to the **WP-80**. Note that <cr> denotes carriage return and <lf> denotes a line feed.

Action	Command	Notes
Request current data	?D<cr>	Returns the current pH, Temperature, date and time from the <b>WP-80</b> . The log number returned is set to Zero.
Request logged data	?R<cr>	Returns all logged records from the <b>WP-80</b> memory. The data ends with the message <b>ENDS</b> <cr>
Erase logged data	?E<cr>	Erases all logged records from the <b>WP-80</b> memory. Returns the message <b>ERASED</b> <cr> to confirm that the records have been erased.
Request status information	?S<cr>	Returns the model name, firmware version number, instrument serial number and number of logged readings in memory, eg: <b>WP-80♦♦V2.0♦R1234♦9999</b> <cr>, where ♦ are spaces. Note that the number of logged readings is right-justified.
Request GLP information	?G<cr>	Returns all calibration GLP information, plus the instrument model and current date (see section 11.6 for data format and handshaking).

### 11.6 Data Format

**A.** Data is returned to the RS232 port by the **WP-80** in the following format when requested by a PC with the ?D or ?R commands (section 11.5):

**LLLL♦DDDDDDUUU♦TTTTTToCm♦dd/mm/yy♦hh:mm:ss<cr>**

**or B.** Data is sent to the RS232 port by the **WP-80** in the following format when it is sent by the **WP-80** using the Print function (section 9.4) or the Instant Send function (section 11.2):

**LLLL♦DDDDDDUUU♦TTTTTToCm♦dd/mm/yy♦hh:mm:ss<cr><lf>**

- where:** **LLLL** is the Log Number. Maximum 4 characters, right justified. The **WP-80** sends a Zero for instant readings (section 11.2)
- ♦ is one space.
- DDDDDD** is the pH, mV or Relative mV Data. Maximum 6 characters, right justified.
- UUU** is the unit description, either pH, mV or mVR
- ♦ is one space.
- TTTTTT** is the Temperature Data. Maximum 6 characters, right justified.
- oCm** is the Temperature unit description. The **WP-80** sends “oC♦” for real temperature data (where ♦ is one space), or “oCm” when manual temperature compensation is being used.
- ♦ is one space.
- dd/mm/yy** is the date, month and year data.
- ♦ is one space.
- hh:mm:ss** is the hours, minutes and seconds data.

C. GLP information is returned as 4 lines terminated by a carriage return.



When using the “?G” command (section 11.5), the computer must respond with a character after receiving each line.

```
eg: WP80 V2.0 R1234 @ 31/12/97 12:00
    pH           Asy=      0.00pH           @ 31/12/97 11:25
    pH           Slope=    100.0%           @ 31/12/97 11:30
    Temperature Offset=    1.0oC           @ 21/12/97 11:35
    ENDS
```

## 12. Battery Saver Function

The **WP-80** is equipped with a battery saver function. If no button has been pressed for five minutes, the unit beeps and flashes the display for 20 seconds, and then shuts off. This function can be switched off for continuous use.

To enable or disable the battery saver function:

1. Switch the meter on. 
2. Select Battery Saver Set-up  → **F4:Setup** → **F1:Batt**
3. The battery saver menu is now displayed.

eg: **Batt Saver** **F1:OFF**  
  **100%→** **F2:ON**

The arrow indicates the current selection.

The bar graph and percentage indicate the approximate level of charge in the battery.

4. Press **F1** to disable the battery saver function for continuous use.  
Press **F2** to enable the battery saver function. The meter will switch itself off if no key has been pressed for five minutes.  
Press  to quit the battery saver menu and retain the current setting.

5. **NOTE:** For troubleshooting purposes, the battery volts can also be displayed in the battery saver menu. Press **F3** to display battery volts.

The  symbol flashes when the battery volts drops below 5.60 volts. At 5.00 volts the meter turns itself off.

## **13. Clock Function**

### **13.1 Setting the Clock**

1. Select the Clock Set-up menu **Menu** → **F4:Setup** → **F2:Clock**
2. The display now shows the current date and time. The cursor starts at the day.

eg: **31/12/96**      **12:00**  
**F1:←** **F2:→**      **↑↓:Set**

3. Press the **▲** and **▼** keys until the day is correct.
4. Press **F2** to move to the month. Press the **▲** and **▼** keys until the month is correct.
5. Press **F2** to move to the year. Press the **▲** and **▼** keys until the year is correct.
6. Press **F2** to move to the hour. Press the **▲** and **▼** keys until the hour is correct.
7. Press **F2** to move the cursor to the minutes. Press the **▲** and **▼** keys until the minutes are correct.
8. Check that the date and time are correct.

Press **F2** to save the settings.

If any changes are needed, press the **F1** key to move left to the desired position.

Press **Menu** to quit without resetting the clock.

### **Notes**



1. The **WP-80** does not test for a valid day of the month when setting the clock (eg: attempting to enter 31/02/96 is not corrected).
2. The **WP-80** does test for leap years.

### **13.2 Displaying or Hiding the Clock**

The date and time are normally displayed along with the pH or mV and Temperature readings. Press **F2** in normal display mode to alternatively display or hide the clock. When Relative mV is selected, the **F2** key alternatively displays the clock or absolute mV.

## **14. Selecting pH6.88 or pH7.00 as the Primary Buffer**

The **WP-80** is factory set to automatically recognise pH6.88 as the primary buffer. However, some users may prefer to use pH7.00. The following procedure describes how to alternate between pH6.88 and pH7.00 as the primary buffer.

1. Switch the meter **OFF** with the  key.
2. Press and HOLD the  key while switching the meter back on.
3. The buffer selection menu is now displayed.

eg **Select** → **F1:6.88pH**  
**Buffer** **F2:7.00pH**

The arrow indicates the current selection.

4. Press  to select pH6.88 as the primary buffer.

Press  to select pH7.00 as the primary buffer.

Press  to quit buffer selection and retain the current setting.



5. The setting is kept in memory when the meter is switched off, even if the battery is removed. The primary buffer is re-set to pH6.88 during initialisation.

**Note:** pH6.88 buffer is a DIN 19266 and NBS Primary-standard pH solution. Its use is highly recommended for the most accurate possible results. If pH7.00 buffer is used, ensure that it is manufactured to 0.01pH accuracy. pH7.00 buffer has a buffer capacity less than half that of pH6.88 buffer and is therefore much less stable.

## **15. Initialising the WP-80**

If the calibration settings of the **WP-80** exceed the allowable limits, the unit may need to be initialised to factory default values. This action may be required if the electrode is replaced.

To initialise the **WP-80**:

1. Switch the **WP-80** off, by pressing the  key.
2. Press and hold the  key while switching the **WP-80** back on.
3. The following messages should be displayed:

**Initialized** then: **WP80s V2.0 R1234**  
**MUST ReCalibrate** **pH mV Temp.**

(The “s” after **WP-80** is shown when the RS232 serial port option is fitted)

4. The meter then displays pH and Temperature. Note that the decimal points have been replaced with a \*, to indicate that the unit requires recalibration.

**Note:** When the **WP-80** is initialised, the primary buffer value is re-set to pH6.88. See section 14 if you wish to select pH7.00 buffer.

## **16. Troubleshooting**

### **16.1 General Errors**

<b>Error Message</b>	<b>Possible Causes</b>	<b>Remedy</b>
<b>Factory Cal. Failed</b> <b>See Handbook</b>	The EEPROM chip which contains the factory calibration information has failed.	The unit must be returned to TPS for service. <ul style="list-style-type: none"> <li>• mV &amp; Temperature readings may be up to 10% incorrect.</li> <li>• pH readings will be accurate after a 2-point calibration (use manual temperature compensation).</li> </ul>
<b>Memory Failed Calibration Lost Initialized MUST ReCalibrate</b>	User calibration settings have been lost or corrupted.	Re-calibrate the instrument. A full 2-point calibration will be required for pH (see section 4.1) and a 1 point calibration for temperature (see section 7.1).
Flashing  symbol.	Battery is below 5.60 volts.	Recharge the battery. Note that the unit will switch itself off when the battery falls below 5.00 volts.
Meter displays the word <b>OFF</b> , and switches off.	Battery is below 5.00 volts.	Recharge the battery. If this fails, check the charger. If charger OK, replace the battery.
Meter will not turn on.	Battery is exhausted.	Recharge the battery. If this fails, check the charger. If charger OK, replace the battery.
Battery does not charge up when charger is connected.	1. Faulty battery charger. 2. Faulty battery.	1. Connect the charger and switch the power on. 2. Display the battery volts in the battery saver menu (see section 12). 3. If the battery volts are increasing then the charger is OK. If the battery volts do not increase, then the charger is faulty. 4. Replace the charger or the battery, as required.

## 16.2 pH and mV Troubleshooting

Symptom	Possible Causes	Remedy
Unit fails to calibrate, even with new probe.	Calibration settings outside of allowable limits due to previous failed calibration.	Initialize the unit. See section 15, Initialising the WP-80.
1 Point calibration fails (Asymmetry is greater than +/-1.00 pH).	<ol style="list-style-type: none"> <li>Reference junction blocked.</li> <li>Reference electrolyte contaminated.</li> </ol>	<p>Clean reference junction, as per instructions supplied with the electrode.</p> <p>Flush with distilled water and replace electrolyte.</p>
2 Point calibration fails (Slope is less than 85.0%).	<ol style="list-style-type: none"> <li>Incorrect primary buffer.</li> <li>Glass bulb not clean.</li> <li>Electrode is aged.</li> <li>Connector is damp.</li> <li>Buffers are inaccurate.</li> </ol>	<p>Ensure that you are using the primary buffer for which the <b>WP-80</b> has been set (see section 14).</p> <p>Clean glass bulb as per instructions supplied with the electrode.</p> <p>Attempt rejuvenation, as per instructions supplied with the electrode. If not successful, replace electrode.</p> <p>Dry in a warm place.</p> <p>Replace buffers.</p>
Unstable readings.	<ol style="list-style-type: none"> <li>Electrolyte chamber needs to be refilled.</li> <li>Reference junction blocked.</li> <li>Glass bulb not clean.</li> <li>Bubble in glass bulb.</li> <li>Faulty connection to meter.</li> <li>Reference junction not immersed.</li> <li>KCl crystals around reference junction, inside the electrolyte chamber.</li> </ol>	<p>Refill with saturated KCl filling solution.</p> <p>Clean reference junction, as per instructions supplied with the electrode.</p> <p>Clean glass bulb as per instructions supplied with the electrode.</p> <p>Flick the electrode to remove bubble.</p> <p>Check connectors. Replace if necessary.</p> <p>Ensure that the bulb AND the reference junction are fully immersed.</p> <p>Rinse electrolyte chamber with warm distilled water until dissolved. Replace electrolyte.</p>

Continued next page...

**pH and mV Troubleshooting, continued...**

Inaccurate readings, even when calibration is successful.	Reference junction blocked.	Clean reference junction, as per instructions supplied with the electrode.
Displays 7.00 for all solutions.	Electrical short in connector.	1. Check connector. Replace if necessary. 2. Replace electrode.
Displays 4-5 pH for all solutions.	Glass bulb or internal stem cracked.	Replace electrode.

**16.3 Temperature Troubleshooting**

<b>Symptom</b>	<b>Possible Causes</b>	<b>Remedy</b>
Displays “Man” when temperature probe is plugged in.	1. Faulty temperature probe.	Fit new temperature probe, part number 121247.
Temperature inaccurate and cannot be calibrated.	1. Faulty connector. 2. Faulty temperature probe.	Check the connector and replace if necessary. Fit new temperature probe, part number 121247.

## **17. Warranty**

TPS Pty. Ltd. guarantees all instruments and electrodes to be free from defects in material and workmanship when subjected to normal use and service. This guarantee is expressly limited to the servicing and/or adjustment of an instrument returned to the Factory, or Authorised Service Station, freight prepaid, within twelve (12) months from the date of delivery, and to the repairing, replacing, or adjusting of parts which upon inspection are found to be defective. Warranty period on electrodes is three (3) months.

There are no express or implied warranties which extend beyond the face hereof, and TPS Pty. Ltd. is not liable for any incidental or consequential damages arising from the use or misuse of this equipment, or from interpretation of information derived from the equipment.

Shipping damage is not covered by this warranty.

### **PLEASE NOTE:**

A guarantee card is packed with the instrument or electrode. This card must be completed at the time of purchase and the registration section returned to TPS Pty. Ltd. within 7 days. No claims will be recognised without the original guarantee card or other proof of purchase. This warranty becomes invalid if modifications or repairs are attempted by unauthorised persons, or the serial number is missing.

### **PROCEDURE FOR SERVICE**

If you feel that this equipment is in need of repair, please re-read the manual. Sometimes, instruments are received for "repair" in perfect working order. This can occur where batteries simply require replacement or re-charging, or where the electrode simply requires cleaning or replacement.

TPS Pty. Ltd. has a fine reputation for prompt and efficient service. In just a few days, our factory service engineers and technicians will examine and repair your equipment to your full satisfaction.

To obtain this service, please follow this procedure:

Return the instrument AND ALL SENSORS to TPS freight pre-paid and insured in its original packing or suitable equivalent. INSIST on a proof of delivery receipt from the carrier for your protection in the case of shipping claims for transit loss or damage. It is your responsibility as the sender to ensure that TPS receives the unit.

Please check that the following is enclosed with your equipment:

- **Your Name and daytime phone number.**
- **Your company name, ORDER number, and return street address.**
- **A description of the fault. (Please be SPECIFIC.)**  
(Note: "Please Repair" does NOT describe a fault.)
- **either \$13.50 for return freight for units under warranty,  
or \$24 to cover inspection costs and return freight.**  
(These amounts are not applicable to full-account customers.)

Your equipment will be repaired and returned to you by air express where possible.

For out-of-warranty units, a repair cost will be calculated from parts and labor costs. If payment is not received for the additional charges within 30 days, or if you decline to have the equipment repaired, the complete unit will be returned to you freight paid, not repaired. For full-account customers, the repair charges will be debited to your account.

- **Always describe the fault in writing.**
- **Always return the sensors with the meter.**

## 18. Appendices

### 18.1 pH Electrode Fundamentals

A combination pH Electrode is two electrodes in one. The sensing membrane is the round or spear shaped bulb at the tip of the electrode. This produces a voltage that changes with the pH of the Solution. This voltage is measured with respect to the second part of the electrode, the reference section. The reference section makes contact with the sample solution using a salt bridge, which is referred to as the reference junction. A saturated solution of KCl is used to make contact with the sample. It is vital that the KCl solution has an adequate flow rate in order to obtain stable, accurate pH measurements.

#### 18.1.1 Asymmetry of a pH Electrode

An "ideal" pH electrode produces 0 mV output at 7.00 pH. In practice, pH electrodes, generally produce 0 mV output at slightly above or below 7.00 pH. The amount of variance from 7.00 pH is called the asymmetry. Figure 18-1 illustrates how asymmetry is expressed.

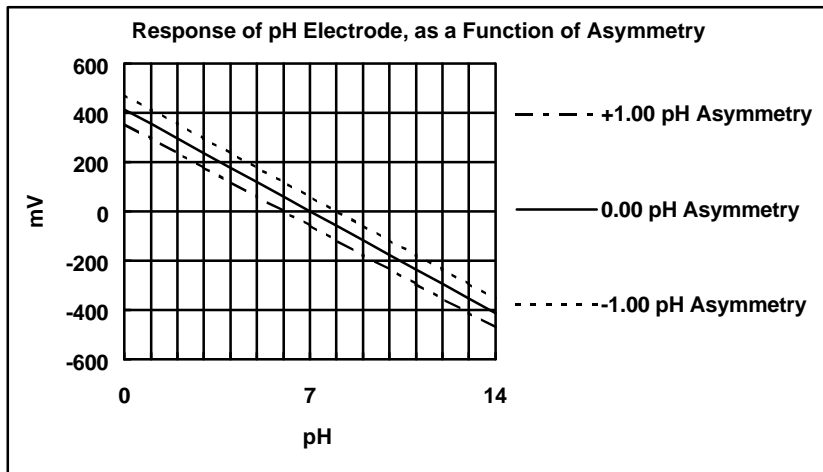

Figure 18-1

18.1.2 The Slope of a pH Electrode

As mentioned above, a pH electrode produces 0 mV output at around 7.00 pH. As the pH goes up, an “ideal” pH electrode produces -59mV/pH unit at 25 °C. As the pH goes down, an ideal pH electrode produces +59mV/pH unit. In practice, pH electrodes usually produce slightly less than this. The output of a pH electrode is expressed as a percentage of an ideal electrode. For example, an ideal electrode that produces 59mV/pH unit has “100% Slope”. An electrode that produces 50.15mV/pH unit has “85% Slope” (see Figure 18-2).

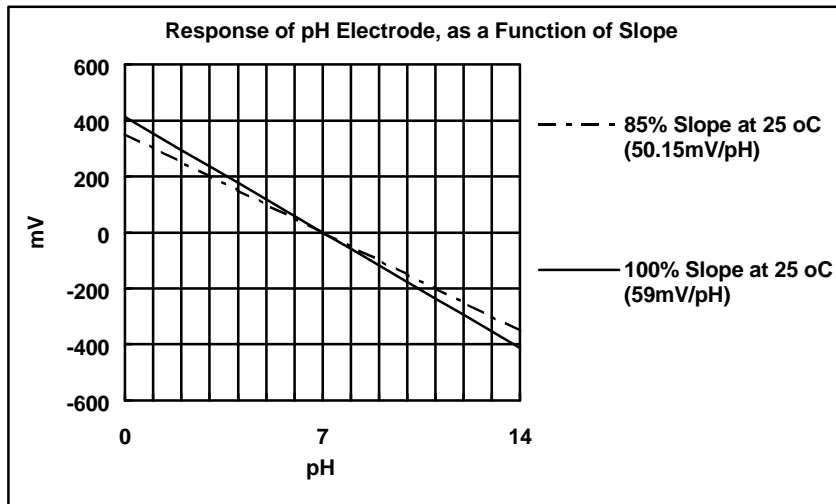

Figure 18-2

### 18.1.3 Temperature Compensation

The slope of a pH electrode (section 18.1.2) is affected by temperature. This effect is compensated for either by using an Automatic Temperature Compensation (ATC) probe or by entering the sample temperature manually. Figure 18-3 shows the slope of a pH electrode at various temperatures.

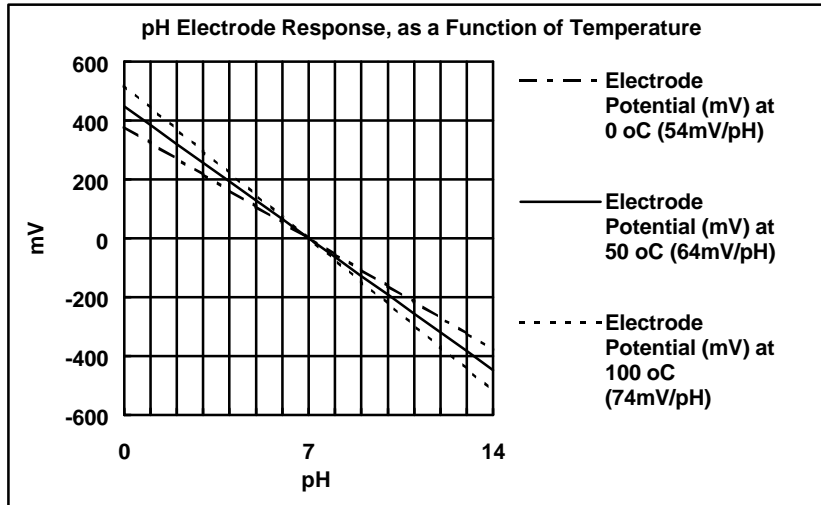

Figure 18-3

### 18.2 Checking the reference junction of a pH electrode.

If pH readings are inaccurate or unstable, the reference junction of the electrode may be blocked. The following test can be performed to determine if the reference junction of a pH electrode is making adequate contact with the sample solution.

1. Calibrate the **WP-80**, as per section 4.1.
2. Dilute 1 part of pH6.88 buffer with 9 parts of distilled water.
3. Measure the pH of the diluted buffer. The result should be 7.06 +/-0.02 pH.
4. If the value obtained is outside of these limits, then clean the reference junction, as per the instructions supplied with the pH electrode.
5. Re-calibrate the **WP-80** and repeat the test.
6. If the value obtained is still outside 7.06 +/-0.02 pH, then the electrode should be replaced.

### 18.3 Determining if an instrument or electrode is faulty

The following test can be performed to help determine if the **WP-80** or the pH electrode is faulty.

1. Initialize the **WP-80** (see section 15).
2. Disconnect the pH electrode.
3. Connect the centre pin of the **pH/mV** connector with the outside frame of the connector, using a short piece of wire or a paper clip etc.
4. The meter should read approximately 7.00. If you press the **Cal** key, the **WP-80** will calibrate to around 6.88 pH, depending upon the temperature readout.
5. If the **WP-80** is operating correctly, the reading should be totally stable with the wire firmly in place. If not, the meter requires servicing.
6. Now carefully disconnect the wire from the centre pin only (make sure the other end of the wire remains connected to the outside frame of the connector).
7. The reading should steadily drift away from 7.00 (either up or down) at a rate of approximately 1 pH or less every 3 seconds. If the drift rate is faster than this, then input circuitry of the **WP-80** is faulty and requires servicing.

### 18.4 Instrument firmware version number.

If you need to phone or fax TPS for any further technical assistance, the version number of your **WP-80** firmware may of benefit to us. The version number is displayed by the **WP-80** at turn-on.