

Congratulations !

Your new **miniCHEM-pH** monitor is the latest in simple, reliable process monitoring instrumentation. With correct operation and maintenance, your **miniCHEM-pH** will give you many years of reliable service.

The **miniCHEM-pH** is a breeze to operate. This manual has been designed to help you get started, and also contains some handy application tips. If at any stage you require assistance, please contact either your local TPS representative or the TPS factory in Brisbane.

The manual is divided into the following sections:

1. Table of Contents

Each major section of the handbook is clearly listed. Sub-sections have also been included to enable you to find the information you need at a glance.

2. Introduction

The introduction has a diagram and explanation of the display and controls of the **miniCHEM-pH**. It also contains a full listing of all of the items that you should have received with the unit. Please take the time to read this section, as it explains some of items that are mentioned in subsequent sections.

3. Main Section

The main section of the handbook provides complete details of the **miniCHEM-pH**, including operating modes, calibration, troubleshooting, specifications, and warranty terms.

4. Appendices

Appendices containing background information and application notes are provided at the back of this manual.

miniCHEM-pH Process Monitor

Version : 2.11
Date : 10/09/2002
Author : MS



TPS Pty Ltd

ABN 30 009 773 371

4 Jamberoo Street
Springwood, Brisbane,
Australia, 4127

Phone : (07) 32 900 400

International : 61 7 32 900 400

Fax : (07) 3808 4871

International : 61 7 3808 4871

Email : tps@tps.com.au

Web : www.tps.com.au

Contents

1. Introduction	4
1.1 miniCHEM-pH Illustration.....	4
1.2 Unpacking Information	6
1.3 Specifications	7
2. Operating Modes	8
3. Installation and Set-up	9
3.1 Connection and Configuration Diagram	9
3.2 Mounting the Enclosure	10
3.3 Mounting the Sensors.....	10
3.4 Terminal Connections	11
3.5 Setting the Control Limit	12
3.6 Selecting Current or Voltage Output	14
3.7 Calibrating the 4 to 20mA Output	15
3.8 CMRR Control.....	15
3.9 Factory Config. Jumpers.....	15
4. Calibration.....	16
4.1 Calibration Procedure.....	16
4.2 Calibration Notes	17
5. Process Monitoring	18
6. Automatic Dosing	18
7. Manual Dosing	18
8. Fuse Replacement	18
9. Troubleshooting	19
9.1 Instrument Function Troubleshooting.....	19
9.2 pH Troubleshooting.....	20
10. Warranty	21
11. Appendices	23
11.1 Checking the reference junction of a pH electrode.	23
11.2 Determining if an instrument or electrode is faulty.....	23
11.3 Terminal connections when 12V DC option is fitted	24
11.4 Relay Output Wiring Examples for mains powered units.....	25
11.5 Relay Output Wiring Examples for 12V DC powered units	26
11.6 Drilling Template	27

1. Introduction

1.1 miniCHEM-pH Illustration

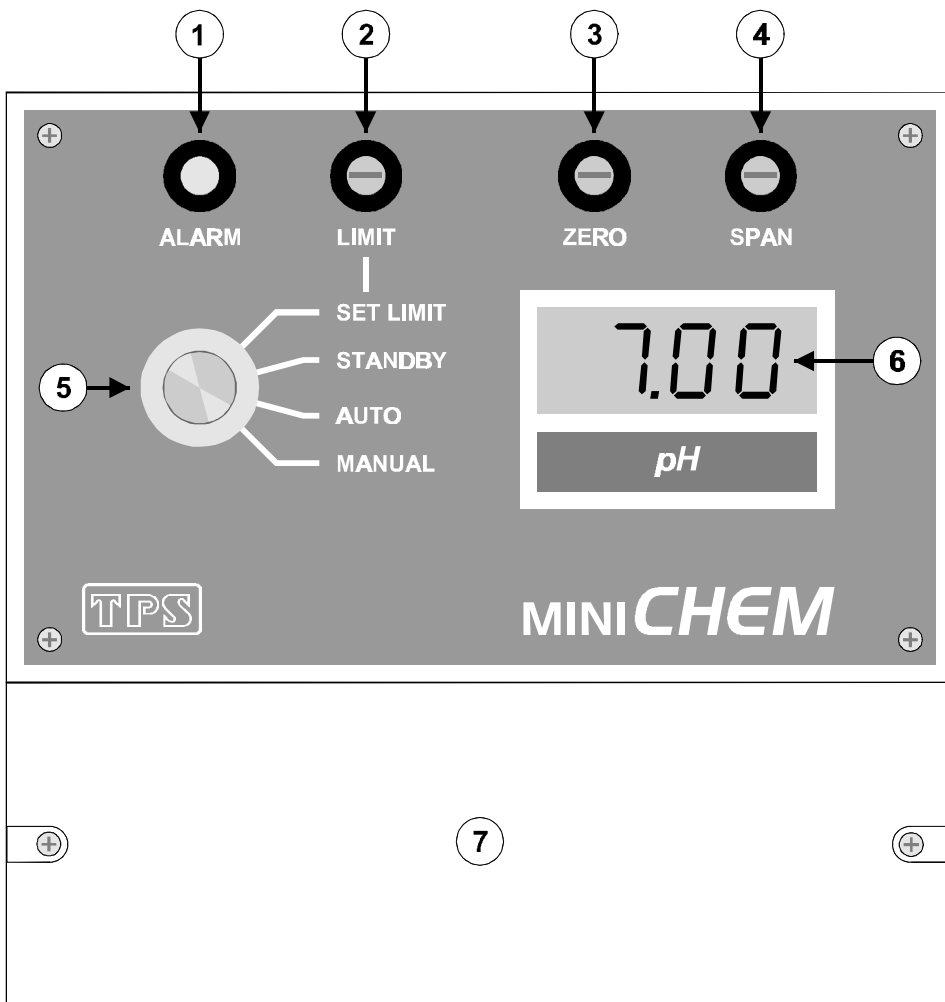

↵ **Alarm LED**

The Alarm LED provides visual indication of when the control limit has been exceeded. The control limit can be set for a “too high” or a “too low” alarm. See section 3.5.

- **Limit Control**

Adjust this control to the pH value at which the Alarm LED and (optional) relay output are activated. See section 3.5.

® **Zero Calibrate Control**

Adjust this control to calibrate the **miniCHEM-pH** in a pH6.88 or pH7.00 buffer. See section 4.1.

- **Span Calibrate Control**

Adjust this control to calibrate the **miniCHEM-pH** in a buffer several pH away from pH7 (e.g. pH4.00 or pH9.23). See section 4.1.

° **Function Switch**

The Function Switch is used to select the mode of operation. See section 2.

± **Display Window**

The **miniCHEM-pH** has a large, easy to read LCD display. The units of measurement are clearly shown in the window beneath the display.

Æ **Terminal Cover**

The terminal cover provides easy access to all of the connections, (optional) relay output fuse, configuration jumpers and user-adjustable trimmers. The cover is water resistant to IP65.

1.2 Unpacking Information

Before using your new **miniCHEM-pH**, please check that the following accessories have been included:

	Part No
1. miniCHEM-pH Process Monitor.....	111140
2. pH6.88 Buffer, 200mL	121306
3. pH4.00 Buffer, 200mL	121381
4. miniCHEM-pH Handbook	130050

Options that may have been ordered with your miniCHEM-pH:

Dip mounted pH and ATC Sensors, and submersible assembly...

1. Submersible, Non-flow pH Sensor, 5m.....	111228
2. Intermediate Junction pH Sensor, 5m.....	111227
3. Industrial 12K ATC Sensor, 5m.....	111275
4. Submersible protective housing for pH & ATC	111303

Screw-in pH and ATC Sensors, and adaptor for 40mm PVC pipe...

1. Screw-in, Non-flow pH Sensor, 5m.....	111244
2. Screw-in Industrial 12K ATC Sensor, 5m	111265
3. ¼" BSP thread adaptor for 40mm PVC pipe	111305

Instrument options...

1. Relay control output.....	130342
2. 4-20mA loop-powered, remote LCD.....	130080

1.3 Specifications

Range	0 to 14.00 pH
Resolution	0.01 pH
Accuracy	±0.01 pH
Linearity	±0.01 pH
Repeatability.....	±0.01 pH
Ambient Drift	<0.01 pH per 10°C change
Long term drift	<0.1% per year
Input Impedance	>3 x 10 ¹² Ω
Asymmetry Range.....	±1.00 pH
Slope Range.....	80 to 110%
Temperature Compensation.....	Automatic, 0 to 100.0 °C (with ATC Sensor), or fixed at 25 °C with 12K resistor.
Common Mode Rejection	120 dB
Enclosure.....	Polycarbonate, waterproof to IP65
Display	12.7 mm LCD (optional remote 4-20mA loop powered display available)
Analogue Outputs	4 to 20mA (500 Ohms max. loop resistance) 0 to 1 V DC (min. load 1000 Ω) 0 to 10 V DC optional (min. load 1000 Ω)
Control Output (optional).....	Clean contact changeover relay, rated to 2A at 240V AC
Isolation.....	Galvanic isolation of sensor input
Power	240V AC, 50/60Hz (120V AC optional)
Dimensions	172 x 160 x 71 mm
Mass	Instrument only : Approx 800g Full Kit : Approx 1.5kg
Operating Environment:	Temperature : 0 to 45 °C Humidity : 0 to 95 % R.H.

2. Operating Modes

The function switch is used to select the required mode. The four operating modes available are...

1. **SET LIMIT** : Switch to **SET LIMIT** when setting the pH value at which the Alarm LED and (optional) relay output are activated. The relay output is not operational in this mode. See section 3.5.
2. **STANDBY** : Switch to **STANDBY** to inhibit the Alarm LED and (optional) output relay action. Select this mode for calibration, or when automatic dosing is not required.
3. **AUTO** : Switch to **AUTO** to enable the Alarm LED and (optional) relay output. These will be activated when the pH is outside the limit value. See section 3.5.
4. **MANUAL** : Switch to **MANUAL** to manually dose acid or base when the optional relay output is fitted. The relay output will be activated for as long as the **miniCHEM-pH** is in this mode, regardless of the pH reading. See section 7.

3. Installation and Set-up

3.1 Connection and Configuration Diagram

The diagram below is provided as a reference for the terminal connections, configuration jumpers and user-adjustable trimmers that are discussed throughout this section.

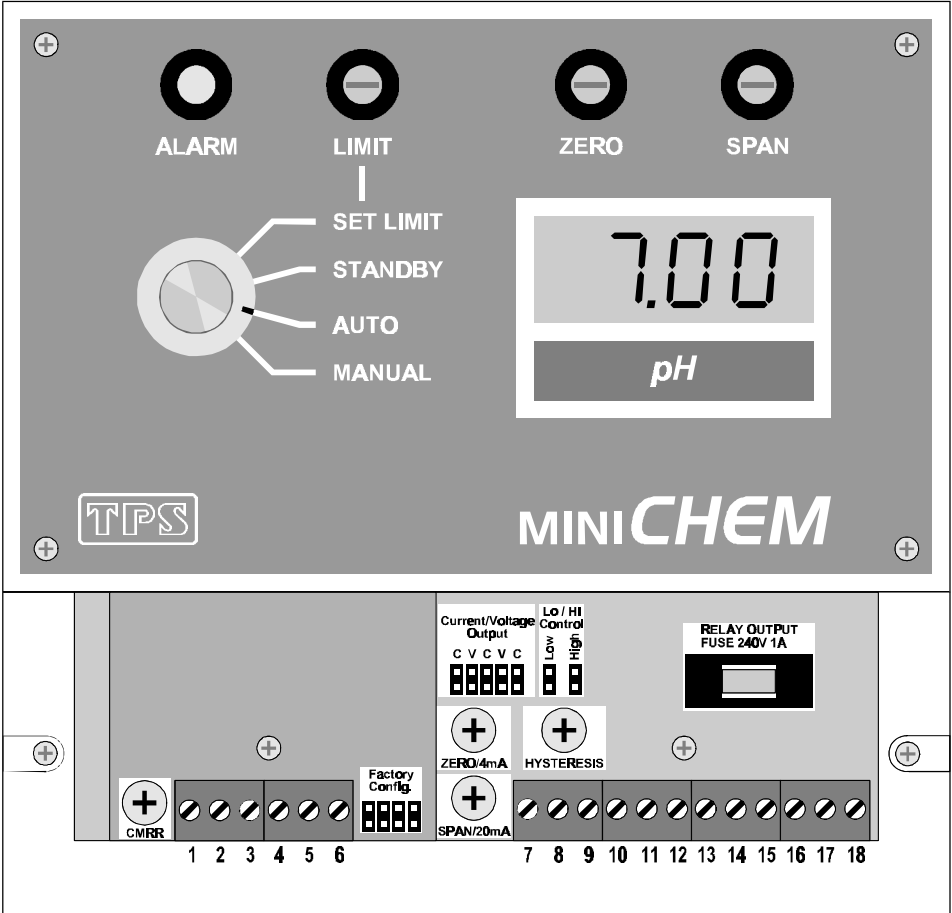

3.2 Mounting the Enclosure

The **miniCHEM-pH** can be wall-mounted with 3 screws. Two mounting points are located underneath the terminal cover, and are positioned so that they do not affect the waterproofing of the enclosure. The third mounting point is centrally located near the top of the rear of the enclosure, and has been designed to hook over a screw-head. The dimensions for the mounting screw centres are provided on the rear of the enclosure. The last page of this manual may be photocopied or removed for use as a drilling template.

3.3 Mounting the Sensors

Mounting the sensors is a very important aspect of the installation, and is often done incorrectly. In automatic control situations, the sensors should always be mounted as close as possible to the injection point. This will cause the sensors to detect the added chemicals immediately, and shut the addition off until mixing has taken place. For in-line mounting, it is important that chemicals are injected upstream. Additionally, the line must be run through a mixing chamber, such as a large drum, to ensure that the injected chemical has mixed in properly by the time the solution flows past the sensors. There must always be adequate flow of fresh sample past the sensor, for accurate monitoring. The diagrams below show typical mounting arrangements for “dip” mounting and in-line mounting.

Dip Mounting

1. Injection point close to sensor.
2. Submersible housing to protect sensors and waterproof rear of cable (part no 111303).
3. Continuous stirring.

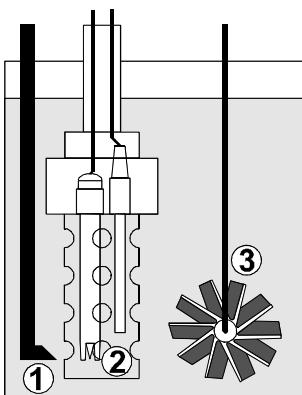

In-line Mounting

1. Injection point upstream from and close to sensor.
2. Mixing container after injection and before sensor.
3. pH sensor mounted as close to vertical as practical.

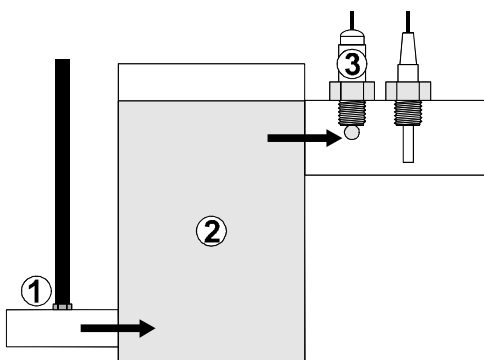

3.4 Terminal Connections

Note: The power connections detailed below are for normal mains power. Refer to section 11.3 for power wiring details when the 12V DC power option is fitted.

Terminal No.	Connection	Colour
1	12K ATC Sensor *	Black
2	12K ATC Sensor Common *	Clear
3	Solution Guard	Green of ATC Sensor OR: Solution guard rod, if no ATC Sensor is installed.
4	pH Shield (if fitted)	Green
5	pH Reference	Black
6	pH Signal	Clear or White
7	+ve of current or voltage output	Customer-defined
8	-ve of current or voltage output	Customer-defined
9	No Connection	
10	Normally Closed contact of (optional) relay output	Customer-defined
11	Common contact of (optional) relay output	Customer-defined
12	Normally Open contact of (optional) relay output	Customer-defined
13	240V AC Active input	Brown (standard colour)
14	Duplicate 240V AC Active contact. See section 11.3.	Brown (standard colour)
15	240V AC Earth input	Green (standard colour)
16	Duplicate 240V AC Earth contact. See section 11.3.	Green (standard colour)
17	240V AC Neutral input	Blue (standard colour)
18	Duplicate 240V AC Neutral contact. See section 11.3.	Blue (standard colour)

* If an ATC sensor is not fitted, then a 12K resistor may be connected between terminals 1 and 2 to simulate 25 °C. If this is done, then a stainless steel solution guard rod must be connected to terminal 3.

3.5 Setting the Control Limit

The control limit can be set over the full scale of the **miniCHEM-pH**, as a “too high” or a “too low” trip point. The hysteresis around this set point can be also be adjusted, if necessary. See section 3.5.3 for an explanation of hysteresis.

3.5.1 Setting the limit value

1. Switch the **miniCHEM-pH** to **SET LIMIT**.

The control limit value is now displayed. Note that the Alarm LED and (optional) output relay are now disabled. The 4-20mA or 0-1V outputs are still active, and proportional to displayed value.

2. Adjust the **LIMIT** control until the display reads the desired trip point value.

3.5.2 Setting the alarm/control direction

The control limit can be set as a “too high” or “too low” trip point using the **Lo/Hi Control** jumpers in the terminal area. The **miniCHEM-pH** must be switched OFF before changing jumper settings.

The jumper settings for a “too low” trip point are...

Low High

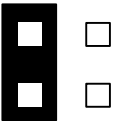

The jumper settings for a “too high” trip point are...

Low High

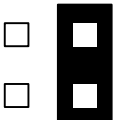

3.5.3 *Adjusting the Hysteresis*

The hysteresis is the pH range over which the alarm/control output remains switched on, once the trip point has been exceeded.

For example, if the limit is set to pH7.00, as a “too low” trip point, with a hysteresis of ± 0.10 pH, the alarm/control output is switched ON when the reading goes to pH6.90 (i.e. $7.00 - 0.10$). The output is not switched OFF until the reading goes back up to pH7.10 (i.e. $7.00 + 0.10$).

The hysteresis stops the relay “chattering” around the set point, by providing a buffer between the points at which the output is switched ON and OFF. This feature can significantly increase the life of pumps and solenoid valves.

The factory-set hysteresis is approximately ± 0.10 pH, as in the example above. The hysteresis can be increased to as high as ± 0.40 pH with the **HYSTERESIS** trimmer in the terminal area. Turning the **HYSTERESIS** clockwise increases the hysteresis and turning it anti-clockwise decreases the hysteresis.

TPS DOES NOT recommend that this setting be altered, unless it is absolutely necessary.

The **HYSTERESIS** trimmer should only be adjusted a little at time. The process being controlled should then be closely monitored over a time to ensure that the desired control is being achieved.

3.6 Selecting Current or Voltage Output

The **Current/Voltage Output** jumpers in terminal section can be user-set for either 4 to 20mA or 0 to 1V DC output. The **miniCHEM-pH** must be switched OFF before changing jumper settings.

The jumper settings for 4 to 20 mA output are:

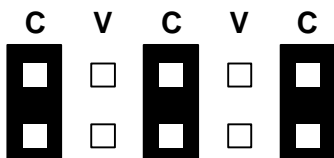

The jumper settings for 0 to 1V DC output are:

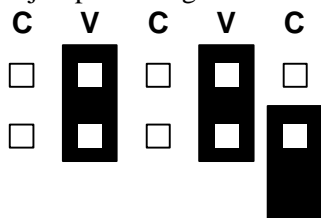

Note that the spare jumper has been fitted to a spare **Current/Voltage Output** jumper pin. This is a safe place to keep it, in case the **miniCHEM-pH** needs to be reset to current output in the future.

0 to 10V DC output is available as a factory fitted option. The jumper settings are the same as detailed above, but the 0 to 1V DC output will no longer be available.

3.7 Calibrating the 4 to 20mA Output

The 4 to 20mA output of the **miniCHEM-pH** is factory calibrated. However, TPS has provided calibration controls for the 4mA and 20mA points in case this requires adjustment in the field. Only a limited amount of adjustment is available, as the **miniCHEM-pH** is designed for 4 to 20mA output for the full scale of the instrument.

Calibrating the 4 to 20mA output...

1. Connect a Digital Milliamp Meter between terminals 7 and 8.
2. Switch the **miniCHEM-pH** to **SET LIMIT**.
3. Adjust the **LIMIT** control until the display reads 0.00.
4. Adjust the **ZERO/4mA** trimmer in the terminal area until the Digital Milliamp Meter reads 4 mA.
5. Adjust the **LIMIT** control until the display reads 14.00.
6. Adjust the **SPAN/20mA** trimmer in the terminal area until the Digital Milliamp Meter reads 20 mA.

*In the event that the **LIMIT** control does not have sufficient adjustment to reach 0.00 or 14.00, calculate the expected output level and use this for calibration. Remember that the difference between 0 and 14 pH is to be made 16mA.*

3.8 CMRR Control

The Common Mode Rejection Ratio (CMRR) is factory-set with the CMRR trimmer.

DO NOT ATTEMPT TO ADJUST THE CMRR TRIMMER.

If this trimmer is accidentally re-set, the unit would best be returned to the factory for re-calibration.

3.9 Factory Config. Jumpers

The **Factory Config.** jumpers are factory set, and must not be altered. In case any of these jumpers are changed or removed, re-fit them as shown below. The **miniCHEM-pH** must be switched OFF before changing jumper settings.

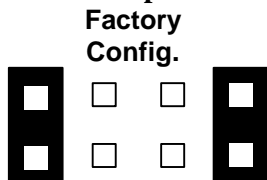

4. Calibration

4.1 Calibration Procedure

1. Switch the **miniCHEM-pH** on.
2. Ensure that the pH and ATC sensors are correctly connected (see section 3.4).
If no ATC sensor is fitted, then a 12K resistor should be connected between terminals 1 and 2. A stainless steel guard rod should then be substituted for the ATC sensor during the calibration procedure detailed below.
3. Set the function switch to **STANDBY**, to ensure that the (optional) relay output is not activated when moving the pH sensor from buffer to buffer.
4. Remove the wetting cap from the pH sensor.
5. Rinse the pH and ATC sensors in distilled water and blot them dry.

Asymmetry (Zero) Calibration

6. Place both sensors into a small sample of pH6.88 or pH7.00 buffer, so that the bulb and reference junction are both covered (see diagram below). **DO NOT** place the electrodes directly into the buffer bottle. Discard the used buffer after use.

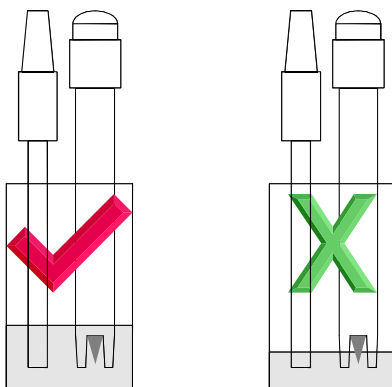

1. When the reading has stabilised, adjust the **ZERO** control until the display shows the value of the buffer. The pH6.88 buffer supplied by TPS lists the pH value of the buffer at various temperatures.
2. Rinse the pH and ATC sensors in distilled water and blot them dry.

Span Calibration

3. Place both sensors into a small sample of pH buffer, that is several pH away from pH7 (e.g. pH4.00 or pH9.23). Ensure that the bulb and reference junction are both covered (see diagram in step 6, above). **DO NOT** place the electrodes directly into the buffer bottle. Discard the used buffer after use.

NOTE: pH buffers above pH9 are highly unstable. Avoid using these buffers if possible. Discard immediately after use.

pH4.00 buffer is recommended for its stability. Most users report readings up to pH12 to be more accurate when using this buffer than when using pH9.23 or pH10.00 buffer for span calibration.

4. When the reading has stabilised, adjust the **SPAN** control until the display shows the value of the buffer. The pH4.00 buffer supplied by TPS lists the pH value of the buffer at various temperatures.
5. Rinse the pH and ATC sensors in distilled water and blot them dry.
6. The **miniCHEM-pH** is now calibrated and ready for pH measurements.

4.2 Calibration Notes

1. An Asymmetry (Zero) calibration should be performed at least weekly. In applications where the electrode junction can become blocked, such as dairy products, mining slurries etc, an asymmetry calibration may have to be done daily.
2. A full 2-point Asymmetry and Span calibration should be performed at least monthly. Of course, more frequent calibration will result in greater confidence in results.

5. Process Monitoring

Once the **miniCHEM-pH** has been installed, connected and calibrated, it can be used for continuous monitoring. To monitor the process, **WITHOUT** any control or alarm functions switch the function switch to **STANDBY**.

6. Automatic Dosing

For Automatic Alarming or Control, switch the function switch to **AUTO** to enable the Alarm LED and the (optional) relay output. These will be switched ON while the pH exceeds the limit value, and will switch OFF once the pH is back within the limit.

7. Manual Dosing

From time to time, a dose of chemical may be required even when the pH is within the limit value. To do this, simply switch the function switch to **MANUAL**, if the (optional) relay output is fitted.

NOTE: The output will be ON continuously while the function switch is set to **MANUAL**. It will not be switched OFF again until the switch is set back to one of the other modes.

8. Fuse Replacement

If the current drain from any device connected to the output relay exceeds 1Amp, the output protection fuse will blow.

To replace the fuse...

1. SWITCH THE **miniCHEM-pH** OFF.
2. Pull out the black fuse carrier.
3. Replace the blown fuse
4. Push the fuse carrier with the new fuse back into place.

ALWAYS REPLACE THE FUSE WITH A 1 AMP, 240V FUSE. USING A FUSE WITH HIGHER CURRENT RATING MAY DAMAGE YOUR CONTROLLER, VOIDING THE WARRANTY.

Before switching the **miniCHEM-pH** back to **AUTO** mode, ensure that the cause of the blown fuse has been eliminated.

If the current drain of the device connected to the relay output is greater than 1 Amp, an external contactor should be used. Please consult an electrical contractor or TPS for details.

9. Troubleshooting

9.1 Instrument Function Troubleshooting

Symptom	Possible Causes	Remedy
No display	<ol style="list-style-type: none"> 1. Mains power input not switched on. 2. Mains power input incorrectly connected. 3. Instrument is faulty. 	<p>Switch power ON.</p> <p>Check connections (see section 3.4).</p> <p>Return to TPS for repair.</p>
Alarm LED or (optional) relay output do not operate when limit is exceeded.	<ol style="list-style-type: none"> 1. Limit not set correctly for “too high” or “too low” alarm/control. 2. Optional relay output not fitted. 3. Hysteresis too large. 4. Fuse has blown. 5. Instrument is faulty. 	<p>Set the Lo/Hi Output jumpers correctly (see section 3.5.2).</p> <p>Return unit to factory to have relay output fitted (part no 130342).</p> <p>Check and adjust the HYSTERESIS trimmer (see section 3.5.3). If in doubt, set this to minimum level.</p> <p>Check and replace fuse if necessary (see section 8).</p> <p>Return to TPS for repair.</p>
Incorrect analogue output signal.	<ol style="list-style-type: none"> 1. Current/Voltage Output jumpers incorrectly set for required output. 2. 4-20mA loop resistance too high. 3. Load on 0-1V DC output is too low. 4. 4-20mA output is not calibrated. 5. Instrument is faulty. 	<p>Check that the Current/Voltage Output jumpers are correctly set for 4-20mA or 0-1V, as per requirements. Adjust if necessary (see section 3.6).</p> <p>Ensure loop resistance does not exceed 500 Ohms.</p> <p>Ensure load is 1000 Ohms minimum.</p> <p>Calibrate 4-20mA output (see section 3.7).</p> <p>Return to TPS for repair.</p>

9.2 pH Troubleshooting

Symptom	Possible Causes	Remedy
Asymmetry (Zero) calibration fails (insufficient range with ZERO control).	<ol style="list-style-type: none"> Reference junction blocked. Reference electrolyte contaminated. 	<p>Clean reference junction, as per instructions supplied with the electrode.</p> <p>Flush with distilled water and replace electrolyte.</p>
Span calibration fails (insufficient range with SPAN control).	<ol style="list-style-type: none"> ATC probe not connected. Glass bulb not clean. Electrode is aged. Buffers are inaccurate. 	<p>Connect ATC probe to terminals 1 & 2 (see section 3.4).</p> <p>Clean glass bulb as per instructions supplied with the electrode.</p> <p>Attempt rejuvenation, as per instructions supplied with the electrode. If not successful, replace electrode.</p> <p>Replace buffers.</p>
Unstable readings.	<ol style="list-style-type: none"> Solution guard not fitted. Reference junction blocked. Glass bulb not clean. Bubble in glass bulb. Reference junction not immersed. KCl crystals around reference junction, inside the electrolyte chamber. 	<p>Connect the green wire from the ATC (or solution guard rod if no ATC sensor is fitted), to terminal 3 (see section 3.4).</p> <p>Clean reference junction, as per instructions supplied with the electrode.</p> <p>Clean glass bulb as per instructions supplied with the electrode.</p> <p>Flick the electrode to remove bubble.</p> <p>Ensure that the bulb AND the reference junction are fully immersed.</p> <p>Rinse electrolyte chamber with warm distilled water until dissolved. Replace electrolyte.</p>
Inaccurate readings, even when calibration is successful.	Reference junction blocked.	Clean reference junction, as per instructions supplied with the electrode.
Displays around 7 pH in all solutions	Electrical short inside electrode or in cable.	Test system with a new electrode and replace if necessary.
Displays 4-5 pH for all solutions.	Glass bulb or internal stem cracked.	Replace electrode.

10. Warranty

TPS Pty. Ltd. guarantees all instruments and electrodes to be free from defects in material and workmanship when subjected to normal use and service. This guarantee is expressly limited to the servicing and/or adjustment of an instrument returned to the Factory, or Authorised Service Station, freight prepaid, within twelve (12) months from the date of delivery, and to the repairing, replacing, or adjusting of parts which upon inspection are found to be defective. Warranty period on electrodes is three (3) months.

There are no express or implied warranties which extend beyond the face hereof, and TPS Pty. Ltd. is not liable for any incidental or consequential damages arising from the use or misuse of this equipment, or from interpretation of information derived from the equipment.

Shipping damage is not covered by this warranty.

PLEASE NOTE:

A guarantee card is packed with the instrument or electrode. This card must be completed at the time of purchase and the registration section returned to TPS Pty. Ltd. within 7 days. No claims will be recognised without the original guarantee card or other proof of purchase. This warranty becomes invalid if modifications or repairs are attempted by unauthorised persons, or the serial number is missing.

PROCEDURE FOR SERVICE

If you feel that this equipment is in need of repair, please re-read the manual. Sometimes, instruments are received for "repair" in perfect working order. This can occur where batteries simply require replacement or re-charging, or where the electrode simply requires cleaning or replacement.

TPS Pty. Ltd. has a fine reputation for prompt and efficient service. In just a few days, our factory service engineers and technicians will examine and repair your equipment to your full satisfaction.

TO OBTAIN THIS SERVICE, PLEASE FOLLOW THIS PROCEDURE:

Return the instrument AND ALL SENSORS to TPS freight pre-paid and insured in its original packing or suitable equivalent. INSIST on a proof of delivery receipt from the carrier for your protection in the case of shipping claims for transit loss or damage. It is your responsibility as the sender to ensure that TPS receives the unit.

Please check that the following is enclosed with your equipment:

- **Your Name and daytime phone number.**
- **Your company name, ORDER number, and return street address.**
- **A description of the fault. (Please be SPECIFIC.)**

(Note: "Please Repair" does NOT describe a fault.)

Your equipment will be repaired and returned to you by air express where possible.

For out-of-warranty units, a repair cost will be calculated from parts and labor costs. If payment is not received for the additional charges within 30 days, or if you decline to have the equipment repaired, the complete unit will be returned to you freight paid, not repaired. For full-account customers, the repair charges will be debited to your account.

- **Always describe the fault in writing.**
- **Always return the sensors with the meter.**

11. Appendices

11.1 Checking the reference junction of a pH electrode.

If pH readings are inaccurate or unstable, the reference junction of the electrode may be blocked. The following test can be performed to determine if the reference junction of a pH electrode is making adequate contact with the sample solution.

1. Calibrate the **miniCHEM-pH**, as per section 4.1.
2. Dilute 1 part of pH6.88 buffer with 9 parts of distilled water.
3. Measure the pH of the diluted buffer. The result should be 7.06 ± 0.02 pH.
4. If the value obtained is outside of these limits, then clean the reference junction, as per the instructions supplied with the pH electrode.
5. Re-calibrate the **miniCHEM-pH** and repeat the test.
6. If the value obtained is still outside 7.06 ± 0.02 pH, then the electrode may need to be replaced, depending on the level of accuracy required.

11.2 Determining if an instrument or electrode is faulty

The following test can be performed to help determine if the **miniCHEM-pH** or the pH electrode is faulty.

1. Disconnect the pH electrode.
2. Connect a short piece of wire or a paper clip etc. between terminals 5 and 6.
3. The **ZERO** control should have sufficient range to obtain a reading of exactly 7.00 on the display.
4. If the **miniCHEM-pH** is operating correctly, the reading should be totally stable with the wire in place. If not, the meter requires servicing.
5. Now carefully disconnect the wire from terminal 6 only (make sure the other end of the wire remains connected to terminal 5).
6. The reading should steadily drift away from 7.00 (either up or down) at a rate of approximately 1 pH or less every 3 seconds. If the drift rate is faster than this, then input circuitry of the **miniCHEM-pH** is faulty and requires servicing.
7. Disconnect the wire from terminal 5. Either re-connect a new pH electrode, or return the **miniCHEM-pH** to the factory or your distributor for servicing.

11.3 Terminal connections when 12V DC option is fitted

Terminal No.	Connection	Colour
1	12K ATC Sensor *	Black
2	12K ATC Sensor *	Clear
3	Solution Guard	Green of ATC Sensor OR: Solution guard rod, if no ATC Sensor is installed.
4	No Connection	
5	pH Reference	Black
6	pH Signal	Clear
7	+ve of current or voltage output	Customer-defined
8	-ve of current or voltage output	Customer-defined
9	No Connection	
10	Normally Closed contact of (optional) relay output	Customer-defined
11	Common contact of (optional) relay output	Customer-defined
12	Normally Open contact of (optional) relay output	Customer-defined
13	No connection for 12V DC version.	
14	Negative of 12V DC Input	Customer-defined
15	No connection for 12V DC version.	
16	No connection for 12V DC version.	
17	No connection for 12V DC version.	
18	Positive of 12V DC Input	Customer-defined

* If an ATC sensor is not fitted, then a 12K resistor may be connected between terminals 1 and 2 to simulate 25 °C. If this is done, then a stainless steel solution guard rod must be connected to terminal 3.

11.4 Relay Output Wiring Examples for mains powered units

The diagrams below provide some examples of wiring the (optional) relay output for standard mains powered **miniCHEM-pH** units.

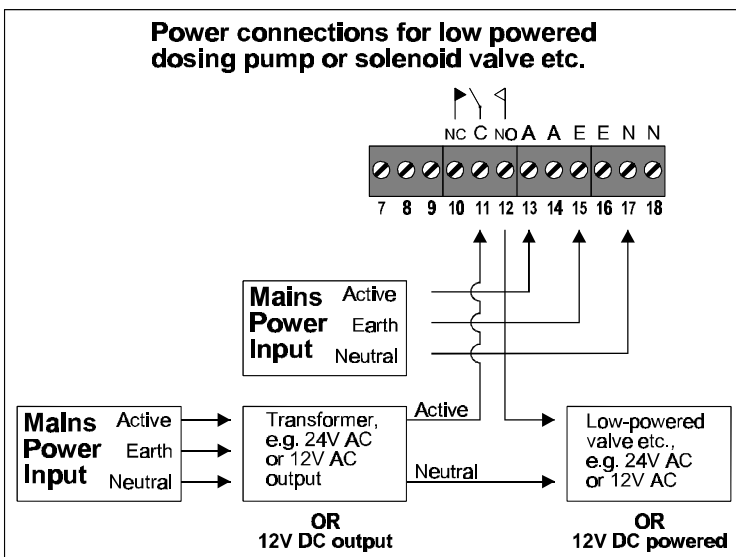
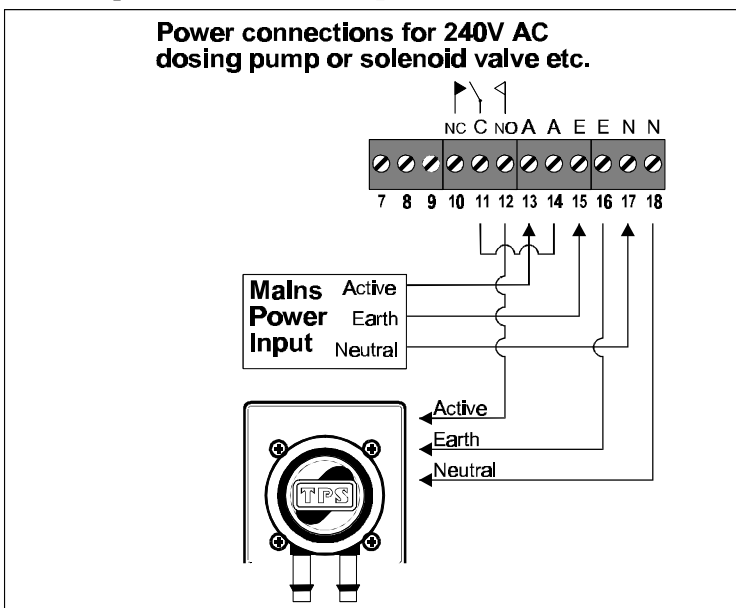

11.5 Relay Output Wiring Examples for 12V DC powered units

The diagrams below provide some examples of wiring the (optional) relay output for **miniCHEM-pH** units with the 12V DC power option.

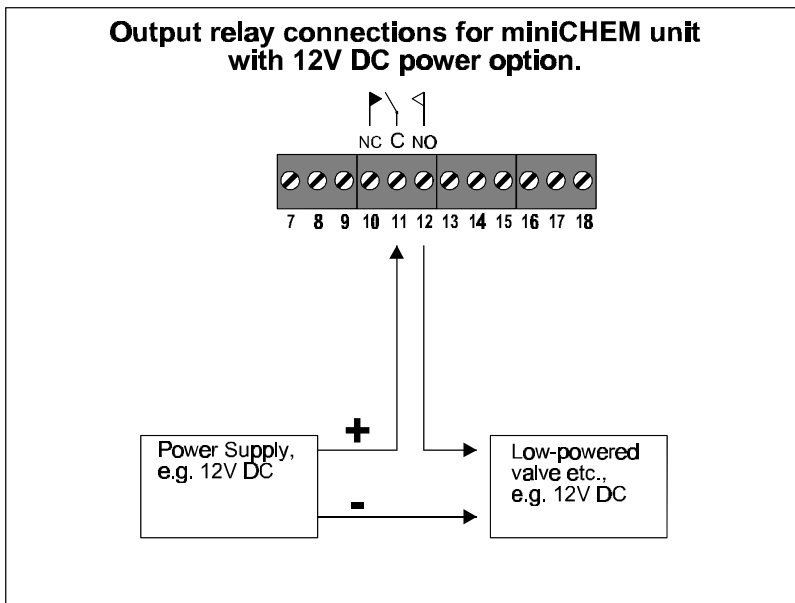

11.6 Drilling Template

The template below is for the three mounting positions for the **miniCHEM** enclosure. This template is actual size, and can be photocopied or removed as required.

