

## **Congratulations !**

Thank you for purchasing a TPS instrument. We trust that your new **MC-85** Sound Level Meter will give you many years of reliable service.

The **MC-85** is easy to operate. This manual has been designed to help you get started, and also contains some handy tips. If at any stage you require assistance, please contact either your local TPS representative or the TPS factory in Brisbane.

---

The manual is divided into the following sections:

### **1. Table of Contents**

Each major section of the handbook is clearly listed. Sub-sections have also been included to enable you to find the information you need at a glance.

### **2. Introduction**

The introduction has a diagram and explanation of the display and controls of the **MC-85**. It also contains a full listing of all of the items that you should have received with your **MC-85**. Please take the time to read this section, as it explains some of items that are mentioned in subsequent sections.

### **3. Main Section**

The main section of the handbook provides complete details of the **MC-85**, including operating modes, troubleshooting, specifications, and warranty terms.

## **Model MC-85 Sound Level Meter**

Handbook Version : 1.01  
Date : 3/3/03  
Author : MS



**TPS Pty Ltd**

4 Jamberoo Street  
Springwood, Brisbane,  
Australia, 4127

Phone : (07) 32 900 400

International : 61 7 32 900 400

Fax : (07) 3808 4871

International : 61 7 3808 4871

E-mail : [tps@tps.com.au](mailto:tps@tps.com.au)

## Contents

|   |           |
|---|-----------|
| <b>1. Introduction</b> .....                                    | <b>4</b>  |
| 1.1 MC-85 Display and Controls.....                             | 4         |
| 1.2 Unpacking Information.....                                  | 6         |
| 1.3 Specifications.....   | 7         |
| <b>2. Measurement Procedure</b> .....                           | <b>8</b>  |
| 2.1 Measurement Notes.....                                      | 8         |
| <b>3. Displaying the Peak Reading</b> .....                     | <b>9</b>  |
| <b>4. Recorder Outputs</b> .....                                | <b>9</b>  |
| <b>5. Calibration</b> .....                                     | <b>10</b> |
| 5.1 Calibration procedure using external sound calibrator.....  | 10        |
| 5.2 Calibration procedure using inbuilt 94dB source.....        | 10        |
| <b>6. Battery Replacement</b> .....                             | <b>11</b> |
| <b>7. Troubleshooting</b> .....                                 | <b>11</b> |
| <b>8. Warranty</b> .....  | <b>12</b> |
| <b>9. A &amp; C Frequency Weighting Characteristics</b> .....   | <b>14</b> |
| <b>10. Fast &amp; Slow Time Weighting Characteristics</b> ..... | <b>14</b> |

# 1. Introduction

## 1.1 MC-85 Display and Controls

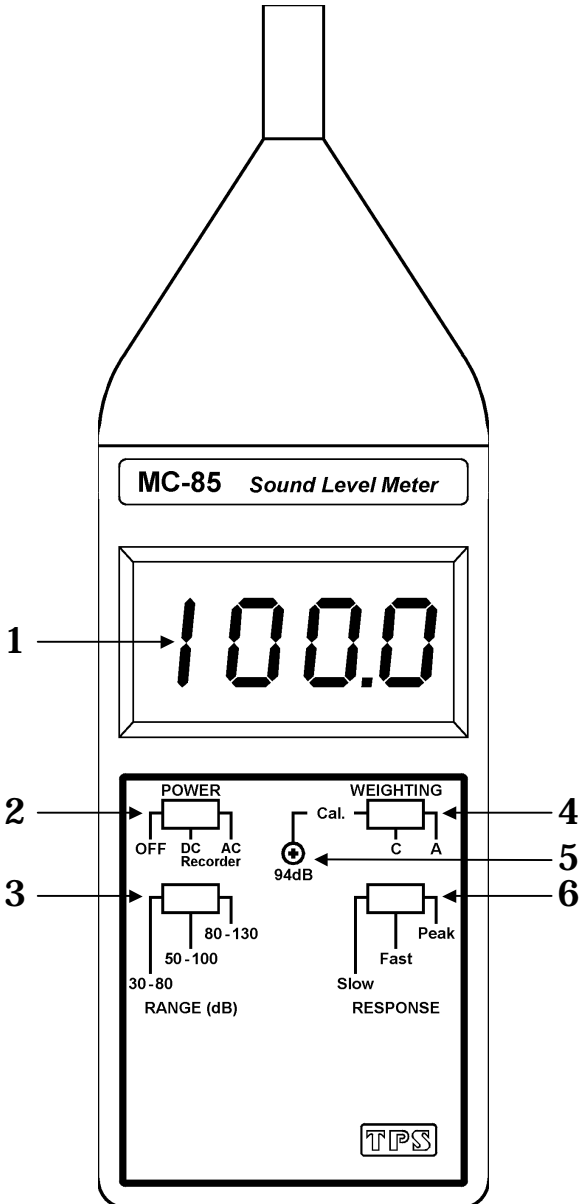

## 1 Display

3½ digit Liquid Crystal Display with 18 mm digits, max display 1999

## 2 Power

Used to switch the **MC-85** on and off. Also used to select DC or AC recorder output signal (see section 4).

## 3 Range (dB)

Selects response range. Choice of 30 to 80, 50 to 100 and 80 to 130 dB.

## 4 Weighting

Selects “A” or “C” frequency weighting for signal.

“A” weighting simulates the characteristics of the human ear and is typically used for making environmental sound level measurements.

“C” weighting is for a flat response, and is used for applications such as checking the noise of machinery.

Switch this control to **Cal.** for calibration using inbuilt 94dB/1kHz generator.

## 5 94dB Calibration Control

Set this control for a precise readout of 94.0 dB when calibrating the **MC-85** on the standard sound calibrator. See section 5 for calibration instructions.

## 6 Response

Selects a Fast or Slow response time weighting and for holding peak values.

Fast response time weighting simulates the response of the human ear.

Slow response time weighting is used for average values of vibration sound levels.

Switch this control to Peak to hold the peak sound level value on the display.

## 1.2 Unpacking Information

Before using your new **MC-85**, please check that the following accessories have been included:

|                                   | Part No |
|-----------------------------------|---------|
| 1. <b>MC-85</b> Sound Level Meter | 125102  |
| 2. 9V Battery                     | 130026  |
| 3. <b>MC-85</b> Handbook          | 130050  |

Options that may have been ordered with your **MC-85**:

|   |        |
|---|--------|
| 1. NiCad Rechargeable battery and charger | 130007 |
| 2. Aluminium Carry Case                   | 130057 |
| 3. External 94dB Sound Calibrator         | SC-940 |

### 1.3 Specifications

|                             |   |                        |                      |                      |                      |                       |                      |                       |                      |                       |  |
|-----------------------------|---|------------------------|----------------------|----------------------|----------------------|-----------------------|----------------------|-----------------------|----------------------|-----------------------|--|
| Ranges                      | : 30 to 80 dB, 50 to 100 dB, 80 to 130 dB   |                        |                      |                      |                      |                       |                      |                       |                      |                       |  |
| Resolution                  | : 0.1 dB  |                        |                      |                      |                      |                       |                      |                       |                      |                       |  |
| Accuracy (at $23 \pm 5$ °C) | : Frequency weighting meets IEC 651 type 2.<br>When calibrated at 94.0 dB (31.5 Hz to 8kHz), accuracy of "A" weighting is as follows... <table> <tr> <td>31.5 Hz : <math>\pm 3.0</math> dB</td> <td>1 kHz : <math>\pm 1.5</math> dB</td> </tr> <tr> <td>63 Hz : <math>\pm 2.0</math> dB</td> <td>2 kHz : <math>\pm 2.0</math> dB</td> </tr> <tr> <td>125 Hz : <math>\pm 1.5</math> dB</td> <td>4 kHz : <math>\pm 3.0</math> dB</td> </tr> <tr> <td>250 Hz : <math>\pm 1.5</math> dB</td> <td>8 kHz : <math>\pm 5.0</math> dB</td> </tr> <tr> <td>500 Hz : <math>\pm 1.5</math> dB</td> <td></td> </tr> </table> | 31.5 Hz : $\pm 3.0$ dB | 1 kHz : $\pm 1.5$ dB | 63 Hz : $\pm 2.0$ dB | 2 kHz : $\pm 2.0$ dB | 125 Hz : $\pm 1.5$ dB | 4 kHz : $\pm 3.0$ dB | 250 Hz : $\pm 1.5$ dB | 8 kHz : $\pm 5.0$ dB | 500 Hz : $\pm 1.5$ dB |  |
| 31.5 Hz : $\pm 3.0$ dB      | 1 kHz : $\pm 1.5$ dB  |                        |                      |                      |                      |                       |                      |                       |                      |                       |  |
| 63 Hz : $\pm 2.0$ dB        | 2 kHz : $\pm 2.0$ dB  |                        |                      |                      |                      |                       |                      |                       |                      |                       |  |
| 125 Hz : $\pm 1.5$ dB       | 4 kHz : $\pm 3.0$ dB  |                        |                      |                      |                      |                       |                      |                       |                      |                       |  |
| 250 Hz : $\pm 1.5$ dB       | 8 kHz : $\pm 5.0$ dB  |                        |                      |                      |                      |                       |                      |                       |                      |                       |  |
| 500 Hz : $\pm 1.5$ dB       |   |                        |                      |                      |                      |                       |                      |                       |                      |                       |  |
| Frequency                   | : 31.5 Hz to 8 kHz  |                        |                      |                      |                      |                       |                      |                       |                      |                       |  |
| Frequency Weighting         | : A Weighting : Simulates the characteristics of the human ear and is typically used for making environmental sound level measurements.<br>C Weighting : Flat response. Used for applications such as checking the vibration noise of machinery.  |                        |                      |                      |                      |                       |                      |                       |                      |                       |  |
| Response Time               | : Fast : 200ms. Simulates the response time of the human ear.<br>Slow : 500ms. Used to obtain an average reading of vibration sound level.  |                        |                      |                      |                      |                       |                      |                       |                      |                       |  |
| Calibration                 | : Via external sound calibrator, or inbuilt 94dB/1kHz generator.  |                        |                      |                      |                      |                       |                      |                       |                      |                       |  |
| Display                     | : 18mm, 3½ Digit Liquid Crystal Display, max display 1999   |                        |                      |                      |                      |                       |                      |                       |                      |                       |  |
| Sensor Type                 | : Condenser microphone, 12.5 mm diameter.   |                        |                      |                      |                      |                       |                      |                       |                      |                       |  |
| Outputs                     | : AC Output : AC 0.5Vrms corresponding to each range step.<br>DC Output : 0.3 to 1.3 VDC, 10mV per dB, 600 Ohms impedance.  |                        |                      |                      |                      |                       |                      |                       |                      |                       |  |
| Power                       | : 9V Alkaline Battery for 75 hours operation.<br>Optional NiCad battery/charger pack available.   |                        |                      |                      |                      |                       |                      |                       |                      |                       |  |
| Dimensions                  | : 247 x 78 x 35 mm  |                        |                      |                      |                      |                       |                      |                       |                      |                       |  |
| Mass                        | : Approx 300g   |                        |                      |                      |                      |                       |                      |                       |                      |                       |  |
| Environment (instrument)    | : Temperature : 0 to 50 °C<br>Humidity : 0 to 90 % R.H.   |                        |                      |                      |                      |                       |                      |                       |                      |                       |  |

## 2. Measurement Procedure

1. Switch the **Power** selector to the **DC Recorder** or **AC Recorder** position. Refer to section 4 for details on the recorder outputs.
2. Switch the **Weighting** selector to **A** or **C** frequency weighting.

**A** weighting simulates the characteristics of the human ear and is typically used for making environmental sound level measurements.

**C** weighting is for a near flat response. This is used for applications such as checking the vibration noise of machinery.

Refer to section 9 for the characteristics of A and C weighting.
3. Switch the **Response** selector to **Fast** or **Slow** time weighting.

Fast response time weighting simulates the response of the human ear.

Slow response time weighting is used for average values of vibration sound levels.

Refer to section 10 for the characteristics of Fast and Slow time weighting.
4. Hold the **MC-85** with the microphone pointing directly towards the sound source. The display will show the sound level in decibels.
5. Switch the **Range** selector to the best range for the measured reading.

For best accuracy, the reading should be around the middle of the selected range.

The **MC-85** will display a **s** if an incorrect range is selected.

### 2.1 Measurement Notes

1. It is important to select the correct frequency weighting for the type of sound being measured. “A” weighting is used for most applications.
2. Selection of the most appropriate range will minimise measurement errors. Ideally, readings should be around the middle of the selected range.
3. Do not store the **MC-85** in areas of high temperature or humidity for long periods.
4. Keep the microphone dry, and avoid excessive shock..

### **3. Displaying the Peak Reading**

When taking measurements in a rapidly changing environment, the operator is able to hold the peak sound level on the display. This allows maximum readings to be correctly noted.

1. To hold the peak sound level on the display, switch the **Response** selector to **Peak**.
2. The peak sound level reading is now displayed. The display is updated if this level is subsequently exceeded, while the **Response** selector is still in the **Peak** position.
3. To resume normal measurement, switch the **Response** selector back to **Fast** or **Slow**.

### **4. Recorder Outputs**

The **MC-85** is fitted with a 3.5mm phono socket for AC or DC recorder output.

Switch the **Power** selector to **AC** to obtain an output of the sound wave form, for recording by a sound analyser, tape recorder etc. The AC output is approx 0.5Vrms corresponding to full scale of selected range.

Switch the **Power** selector to **DC** to obtain a DC voltage output, proportional to the reading on the display. This can be output to a chart recorder, controller etc. The DC output is 10mV per decibel.

## **5. Calibration**

The **MC-85** is supplied pre-calibrated. Re-calibration will be required periodically (approx annually), depending on the accuracy required. For optimum accuracy, the unit should be calibrated with external sound calibrator. To check the amplifier circuits, the **MC-85** can also be calibrated using an inbuilt 94dB/1kHz source.

### **5.1 Calibration procedure using external sound calibrator.**

1. A sound calibrator unit is required. TPS offers a model SC-940 as an option. The sound calibrator must fit a 12.5mm microphone, and generate 94db at 1kHz.
2. Fit the sound calibrator snugly over the **MC-85** microphone
3. Switch the **Power** selector to the **DC Recorder** or **AC Recorder** position. Switch the **Weighting** selector to **A**. Switch the **Response** selector to **Slow**. Switch the **Range** selector to **50-100**. Wait for the displayed sound level reading to stabilise.
4. Adjust the **94dB Calibration Control** with a small Philips head screwdriver until the display shows  $94.0 \pm 0.2$  dB.
5. The **MC-85** is now calibrated and can be used for accurate sound level measurements.

### **5.2 Calibration procedure using inbuilt 94dB source**

1. Switch the **Power** selector to the **DC Recorder** or **AC Recorder** position. Switch the **Response** selector to **Slow**. Switch the **Range** selector to **50-100**. Switch the **Weighting** selector to **Cal**. Wait for the displayed sound level reading to stabilise.
2. Adjust the **94dB Calibration Control** with a small Philips head screwdriver until the display shows  $94.0 \pm 0.2$  dB.
3. The **MC-85** internal amplifier circuit is now calibrated and operational.

## 6. Battery Replacement

1. When the battery volts drops below 6.5-7.5V the display shows “**BAT**” in the lower left hand corner. When this occurs the battery must be replaced as soon as possible, otherwise readings will become inaccurate.
2. Loosen the battery cover screw on the rear of the **MC-85** and slide the battery cover away.
3. Remove the battery and replace it with a new 9V battery. Alkaline batteries are preferred.
4. Replace the battery cover and re-tighten the screw.

## 7. Troubleshooting

| Symptom                                      | Possible Causes   | Remedy   |
|--|---|--|
| Unstable readings                            | <ol style="list-style-type: none"> <li>1. Battery is low</li> <li>2. Requires re-calibration</li> <li>3. Microphone is faulty.</li> </ol> | Replace battery.<br>Re-calibrate meter.<br>Return to factory for repair.   |
| Display shows just “1 .” or “-1 .”           | <ol style="list-style-type: none"> <li>1. Meter has over-ranged.</li> <li>2. Instrument or sensor is faulty.</li> </ol>                   | Check that the sound level readings are within the specified ranges (section 2)<br>Return to factory for repair. |
| Meter will not turn on.                      | Battery is exhausted.   | Replace the battery.   |
| Reading does not change. Fixed at one value. | <b>Response</b> selector switched to <b>Peak</b> position.  | Switch back to <b>DC Recorder</b> or <b>AC Recorder</b> for normal operation.                                    |

## **8. Warranty**

TPS Pty. Ltd. guarantees all instruments and electrodes to be free from defects in material and workmanship when subjected to normal use and service. This guarantee is expressly limited to the servicing and/or adjustment of an instrument returned to the Factory, or Authorised Service Station, freight prepaid, within twelve (12) months from the date of delivery, and to the repairing, replacing, or adjusting of parts which upon inspection are found to be defective. Warranty period on electrodes is three (3) months.

There are no express or implied warranties which extend beyond the face hereof, and TPS Pty. Ltd. is not liable for any incidental or consequential damages arising from the use or misuse of this equipment, or from interpretation of information derived from the equipment.

Shipping damage is not covered by this warranty.

### **PLEASE NOTE:**

A guarantee card is packed with the instrument or electrode. This card must be completed at the time of purchase and the registration section returned to TPS Pty. Ltd. within 7 days. No claims will be recognised without the original guarantee card or other proof of purchase. This warranty becomes invalid if modifications or repairs are attempted by unauthorised persons, or the serial number is missing.

### **PROCEDURE FOR SERVICE**

If you feel that this equipment is in need of repair, please re-read the manual. Sometimes, instruments are received for "repair" in perfect working order. This can occur where batteries simply require replacement or re-charging, or where the electrode simply requires cleaning or replacement.

TPS Pty. Ltd. has a fine reputation for prompt and efficient service. In just a few days, our factory service engineers and technicians will examine and repair your equipment to your full satisfaction.

To obtain this service, please follow this procedure:

Return the instrument to TPS freight pre-paid and insured in its original packing or suitable equivalent. INSIST on a proof of delivery receipt from the carrier for your protection in the case of shipping claims for transit loss or damage. It is your responsibility as the sender to ensure that TPS receives the unit.

Please check that the following is enclosed with your equipment:

- **Your Name and daytime phone number.**
- **Your company name, ORDER number, and return street address.**
- **A description of the fault. (Please be SPECIFIC.)**  
(Note: "Please Repair" does NOT describe a fault.)
- **either \$13.50 for return freight for units under warranty,  
or \$24 to cover inspection costs and return freight.**

(These amounts are not applicable to full-account customers.)

Your equipment will be repaired and returned to you by air express where possible.

For out-of-warranty units, a repair cost will be calculated from parts and labor costs. If payment is not received for the additional charges within 30 days, or if you decline to have the equipment repaired, the complete unit will be returned to you freight paid, not repaired. For full-account customers, the repair charges will be debited to your account.

- **Always describe the fault in writing.**

**9. A & C Frequency Weighting Characteristics**

| Frequency<br>Hz | A Weighting<br>Characteristics | C Weighting<br>Characteristics | Tolerance<br>(IEC 651 type 2) |
|-----------------|--------------------------------|--------------------------------|-------------------------------|
| 31.5            | -39.4 dB                       | -3 dB                          | $\pm 3.0$ dB                  |
| 63              | -26.2 dB                       | -0.8 dB                        | $\pm 2.0$ dB                  |
| 125             | -16.1 dB                       | -0.2 dB                        | $\pm 1.5$ dB                  |
| 250             | -8.6 dB                        | 0 dB                           | $\pm 1.5$ dB                  |
| 500             | -3.2 dB                        | 0 dB                           | $\pm 1.5$ dB                  |
| 1 k             | 0 dB                           | 0 dB                           | $\pm 1.5$ dB                  |
| 2 k             | +1.2 dB                        | -0.2 dB                        | $\pm 2.0$ dB                  |
| 4 k             | +1 dB                          | -0.8 dB                        | $\pm 3.0$ dB                  |
| 8 k             | -1.1 dB                        | -3 dB                          | $\pm 5.0$ dB                  |

**10. Fast & Slow Time Weighting Characteristics**

| Time Weighting | Max. response<br>ref. continuous<br>signal | Tolerance<br>(IEC 651 type 2) |
|----------------|--|-------------------------------|
| Fast (200ms)   | -1.0 dB                                    | +1 dB,<br>- 2 dB              |
| Slow (500ms)   | -4.1 dB                                    | - 2 dB                        |